



# HP 425/550 MANURE SPREADER

# PARTS BOOK



Revision #06  
425 Starting Serial # 514315  
550 Starting Serial # 315147

HSMFG0814

Part #59746

Manufactured By  
**H&S MANUFACTURING CO., INC.**

P.O. BOX 768 (715) 387-3414 FAX (715) 384-5463  
MARSHFIELD, WISCONSIN 54449

# CONTENTS

Instructions for Ordering Parts .....	1
Figure 1 - Frame Assembly .....	2-5
Figure 2 - Tandem Axle .....	6-9
Figure 3 - Beater Drive Train .....	10-13
Figure 4 - Endgate .....	14-15
Figure 5 - Beaters .....	16-19
Figure 6 - Pusher .....	20-23
Figure 7 - Pusher and Endgate hyd. Components .....	24-27
Figure 8 - Endgate Cylinder .....	28-29
Figure 9 - Hydraulic Pusher Cylinder .....	30-31
Figure 10 - Beater Gearbox .....	32-33
Figure 11 - Vertical Beater Frame (425) .....	34-37
Figure 12 - Vertical Beater Frame ( 550) .....	38-41
Figure 13 - Vertical Beater Drive Train .....	42-45
Figure 14 - Superior Gearbox Left .....	46
Figure 15 - Superior Gearbox Right .....	47
Figure 16 - Chain Oiler .....	48-49
Figure 17 - Optional Lighting .....	50
Figure 18 - Optional Rear Pan .....	51
Figure 19 - Pto (1000 Rpm) .....	52
Figure 20 - Pto (540 Rpm) .....	53
Figure 21 - Optional Tandem (550) .....	54-55

# **INSTRUCTIONS FOR ORDERING PARTS**

All service parts should be ordered through your authorized H&S dealer. He will be able to give you faster service if you will provide them with the following:

1. Model & Serial Number - Both can be located on the side of the center bearing post above jack mount.
2. All references to left or right apply to the machine as viewed from the rear.
3. Parts should not be ordered from illustration only. Please order complete part number.
4. If your dealer has to order parts - give shipping instructions:

VIA truck - large pieces (please specify local truck lines)

VIA United Parcel Service (include full address)

H&S MFG. CO. INC.	
MARSHFIELD, WIS.	
MOD. NO.	<input type="text"/>
SER. NO.	<input type="text"/>
DESCR.	<input type="text"/>

PLEASE RECORD NUMBERS FOR YOUR UNIT FOR QUICK REFERENCE

## **ABOUT IMPROVEMENTS**

H&S IS CONTINUALLY STRIVING TO IMPROVE IT'S PRODUCTS

We must therefore, reserve the right to make improvements or changes whenever it becomes practical to do so, without incurring any obligation to make changes or additions to the equipment previously sold.

# FIGURE 1

## FRAME ASSEMBLY

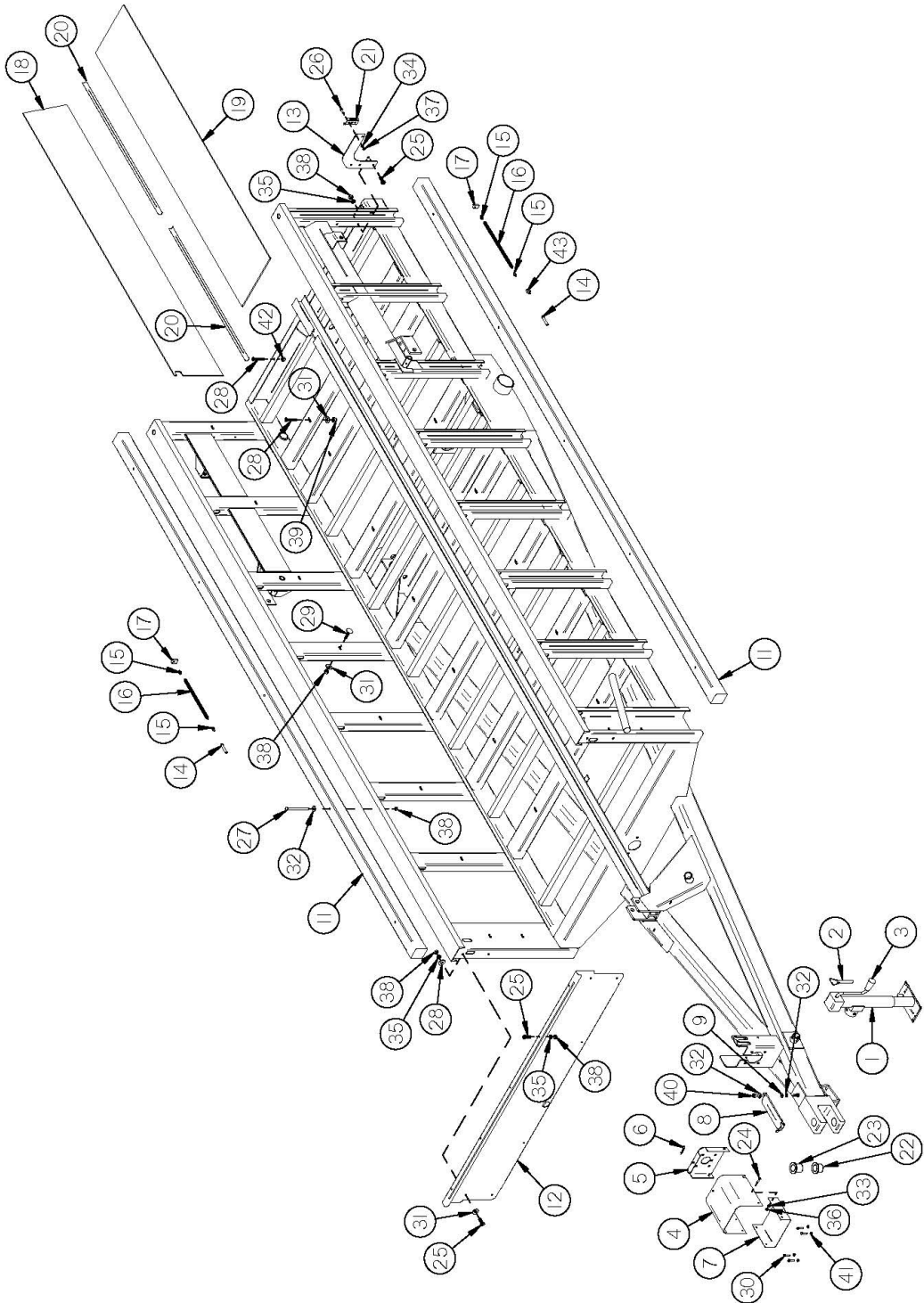

# FIGURE 1

## FRAME ASSEMBLY

<u>QTY</u>				
<u>ITEM</u>	<u>HP425</u>	<u>HP550</u>	<u>PART #</u>	<u>DESCRIPTION</u>
1	1	"	27N49	JACK
2	1	"	27N50	TJP-PN58 5/8" PIN & CHAIN
3	1	"	12N119	JACK HANDLE
4	1	"	16SV329	PTO SHIELD
5	1	"	42N1	SHIELD MOUNT
*	2	"	YMRV10005	5/16" X 1 SLD RIVET FLT NAIL HD PLAIN
6	1	"	YPHR02005	HAIR PIN, #21-05 (1-7/8" LONG, 3/8-7/16" SHAFT)
7	1	"	16SV327	PTO SHIELD BOTTOM
8	1	"	42N2	PTO HOLDER
9	1	"	42N3	SPRING
10	1	"	12N14	JACK MOUNT
11	2	"	42N4	WOOD RAIL
12	1	-----	42N5	FRONT PANEL
*	-----	1	55N1	FRONT PANEL
13	1	"	42N43	SMV BRACKET
14	2	"	66077	NIPPLE, 1/8" MALE PIPE X 2-1/2"
15	4	"	S47	GREASE FITTING
16	2	"	42N41	GREASE LINE
17	2	"	16V9	GREASE BRACKET
18	1	-----	42N8	SIDE POLY RIGHT
*	-----	1	55N4	SIDE POLY RIGHT
*	1	-----	42N9	SIDE POLY LEFT
*	-----	1	55N5	SIDE POLY LEFT
19	1	"	42N10	FLOOR POLY RIGHT
*	1	"	42N11	FLOOR POLY LEFT
		"	42N12	POLY SIDE ANGLE

**NOTE: \* MEANS NOT SHOWN**

**- MEANS NOT USED ON THIS MODEL**

**" MEANS SAME AS PREVIOUS MODEL**

# FIGURE 1

## FRAME ASSEMBLY

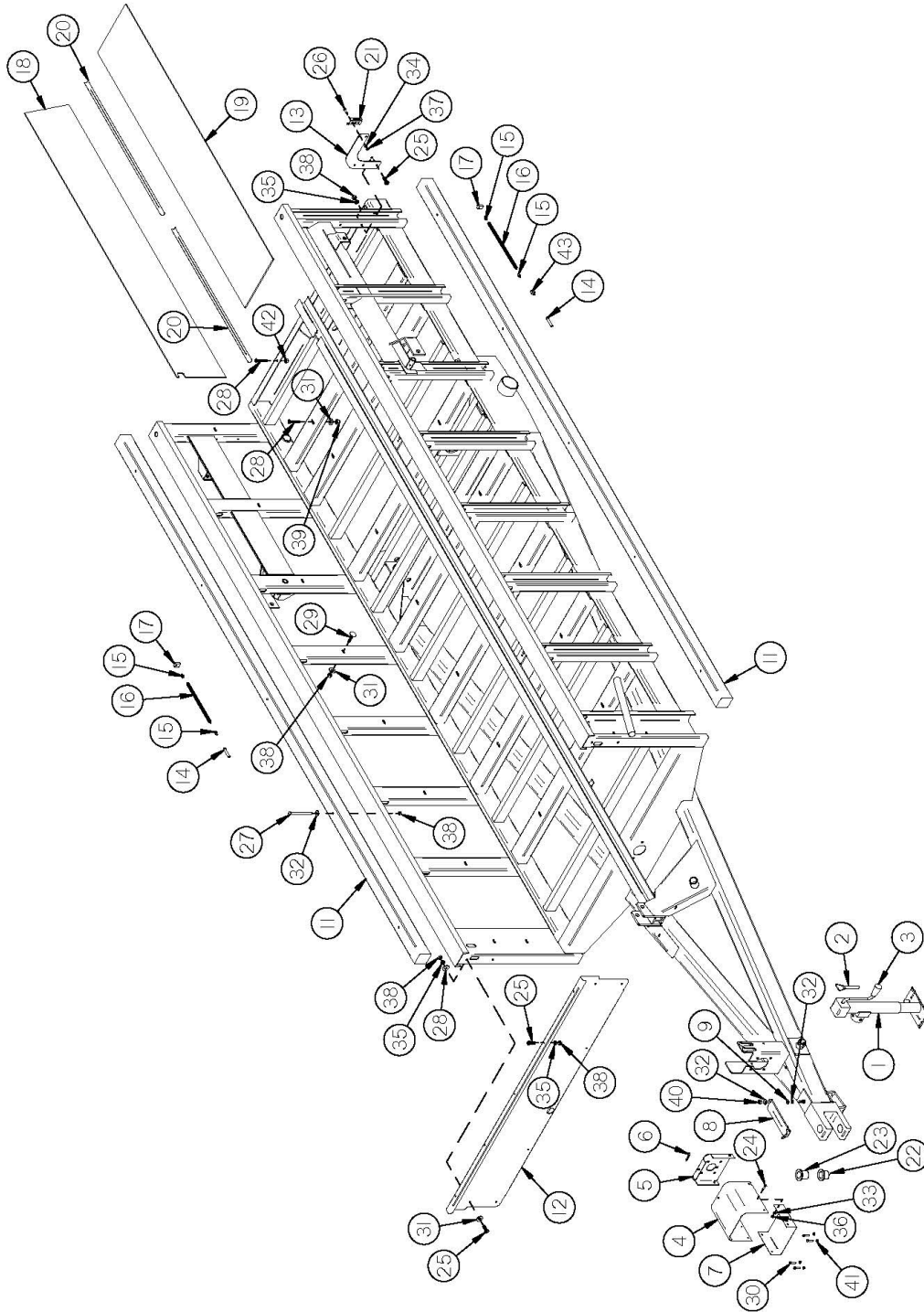

# FIGURE 1

## FRAME ASSEMBLY

<u>QTY</u>				
<u>ITEM</u>	<u>HP425</u>	<u>HP550</u>	<u>PART#</u>	<u>DESCRIPTION</u>
20	4	"	42N12	POLY SIDE ANGLE
21	1	"	F97	SMV HOLDER
22	1	"	42N166	HITCH PIN BUSHING BOTTOM (OPTIONAL)
23	1	"	42N167	HITCH PIN BUSHING TOP (OPTIONAL)
24	4	"	YBHH08010	BOLT, 1/4" X 1" GR. 5
25	11	"	YBHH12010	BOLT, 3/8" X 1" GR. 5
26	2	"	YBCR10030	CARR. BOLT, 5/16" X 3/4" GR. 5
27	10	"	YBCR12105	CARR. BOLT, 3/8" X 4-1/2" GR. 5 FULL THREAD
28	20	"	YSFS12005	FLAT HEAD SOCKET CAP SCREW 3/8"-16 X 1-1/4" GR 5. ZINC
29	18	38	YBPL12010	#3 FLAT HEAD PLOW BOLT, 3/8"-16 X 1-1/4" GR. 5, ZINC
30	4	"	YBHH10070	SHEAR BOLT 5/16" x 2" GR. 5 (1000 RPM)
*	4	---	YBHH10075	SHEAR BOLT 5/16" x 2" GR.8 (540 RPM)
31	40	60	YWFL12005	WASHER, FLAT, 3/8" USS
32	12	"	YWFL14005	WASHER, FLAT, 7/16" USS
33	4	"	YWLO08005	WASHER, LOCK, 1/4"
34	2	"	YWLO10005	WASHER, LOCK, 5/16"
35	11	"	YWLO12005	WASHER, LOCK, 3/8"
36	4	"	YNHX08005	HEX NUT, 1/4"-20
37	2	"	YNHX10005	HEX NUT, 5/16"
38	39	59	YNHX12005	HEX NUT, 3/8"-16
39	14	"	YNNY12005	HEX NUT, NYLON LOCKNUT, 3/8"
40	1	"	YNNY16005	HEX NUT, NYLON LOCKNUT, 1/2"
41	4	"	YNRL10005	HEX NUT, REVERSIBLE-SIDE LOCK, 5/16"-18
42	6	"	YNTL12005	HEX NUT, TOP LOCK, 3/8"-16
43	1	"	66079	HEX ADAPTER, 1/4" FEMALE & 1/8" FEMALE PIPE

**NOTE: \* MEANS NOT SHOWN**  
**- MEANS NOT USED ON THIS MODEL**  
**" MEANS SAME AS PREVIOUS MODEL**

# FIGURE 2

## TANDEM AXLE

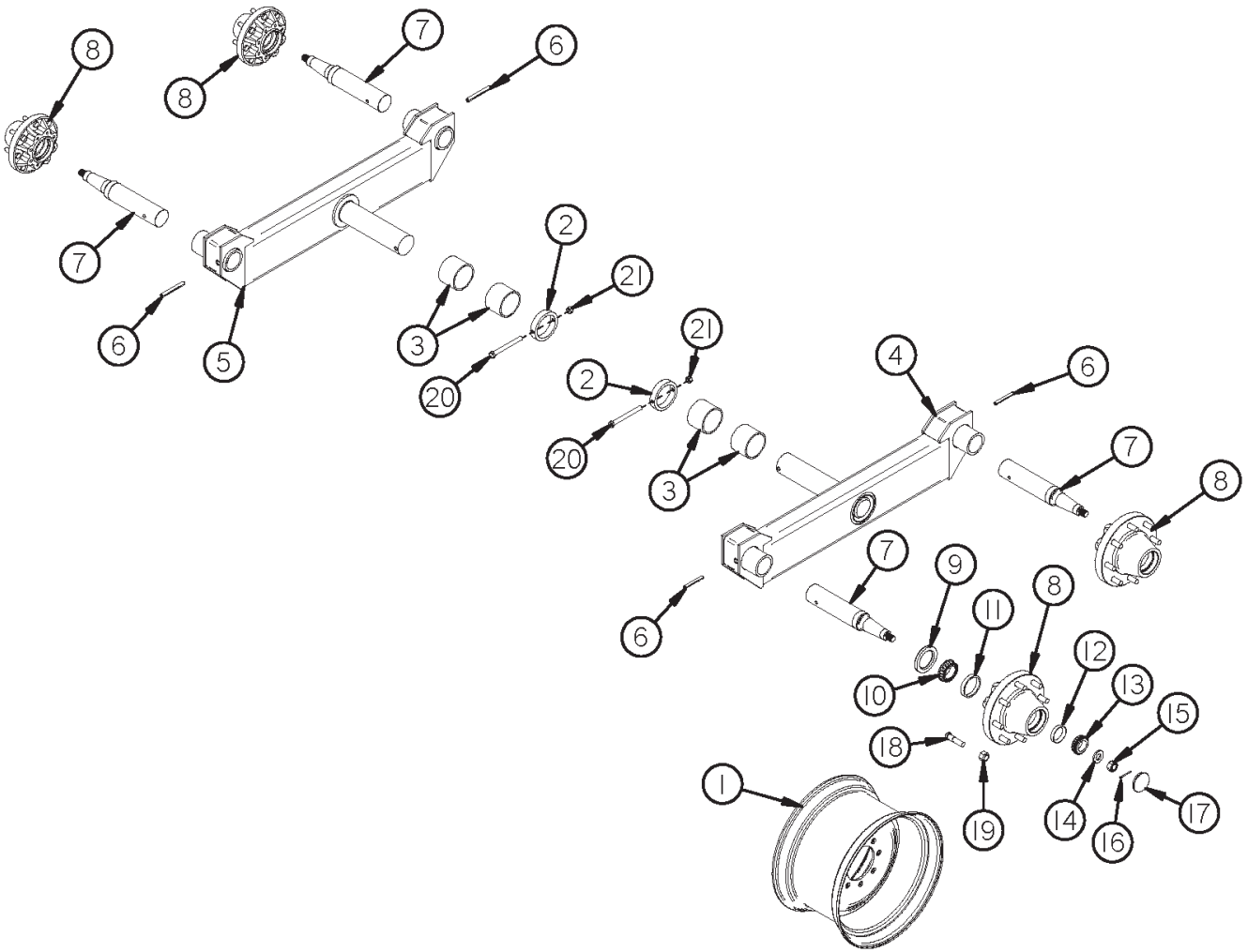



## FIGURE 2

### TANDEM AXLE

<u>QTY</u>				
<u>ITEM</u>	<u>HP425</u>	<u>HP550</u>	<u>PART#</u>	<u>DESCRIPTION</u>
1	4	—	16SV89	WHEEL 13.5 X 22.5
*	—	4	60N15	WHEEL 13.5 X 22.5 (10 Bolt)
*	—	4	16SV88	TIRE (425 X 22.5 TRUCK)
*	4	—	42N138	TIRE (385 x 22.5 TRUCK)
OPT.	4	—	12V36	WHEEL 16.1 X 14 (8 Bolt)
OPT.	4	—	23N54	TIRE (16.5 X 16.1 FLOTATION)
2	2	—	45N35	COLLAR FOR AXLE
*	—	2	16SV214	COLLAR FOR AXLE
3	4	—	45N36	BUSHING FOR TANDEM AXLE
*	—	4	16SV75	BUSHING FOR TANDEM AXLE
4	1	—	42N6	TANDEM AXLE LEFT
*	—	1	55N2	TANDEM AXLE LEFT
5	1	—	42N7	TANDEM AXLE RIGHT
*	—	1	55N3	TANDEM AXLE RIGHT
6	4	"	31N14	ROLL PIN
7	4	—	33SV40	SPINDLE
*	—	4	66N15	SPINDLE
8	4	—	33SV45	HUB
*	4	—	RG275	758(B) HUB WITH BEARINGS
*	—	4	60N8	HUB
9	4	—	33SV42	SEAL
*	—	4	60N5	SEAL
10	4	—	33SV43	INNER BEARING
*	—	4	60N7	INNER BEARING

**NOTE: \* MEANS NOT SHOWN**

**— MEANS NOT USED ON THIS MODEL**

**" MEANS SAME AS PREVIOUS MODEL**

# FIGURE 2

## TANDEM AXLE

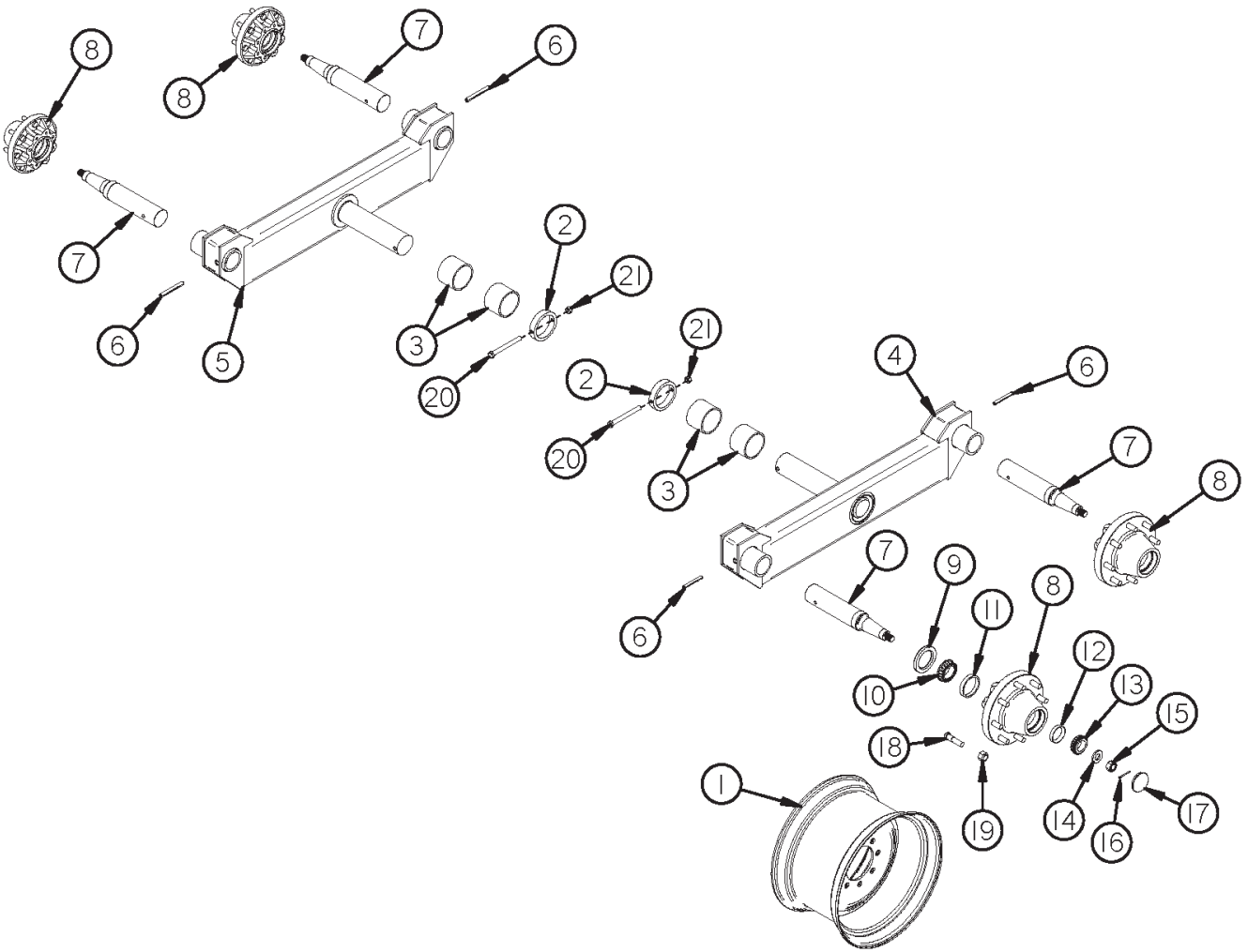

## FIGURE 2

### TANDEM AXLE

<u>QTY</u>				
<u>ITEM</u>	<u>HP425</u>	<u>HP550</u>	<u>PART #</u>	<u>DESCRIPTION</u>
11	4	---	33SV44	INNER RACE
*	---	4	60N6	INNER RACE
12	4	---	RG169	OUTER RACE
*	---	4	60N10	OUTER RACE
13	4	---	RG170	OUTER BEARING
*	---	4	60N9	OUTER BEARING
14	4	---	33SV95	WASHER
*	---	4	60N2	WASHER
15	4	---	YNSL32005	HEX NUT, SLOTTED, 1"-14
*	---	4	YNCA36005	HEX NUT, CASTLE, 1-1/4"-12
16	4	---	33SV46	COTTER PIN
*	---	4	YPCT05010	COTTER PIN, 5/32" X 1-1/2"
17	4	---	RG171	HUB CAP
*	---	4	60N11	HUB CAP
18	32	---	YBSD20010	STUD BOLT, 5/8"-18 UNF X 2-1/2" (7/8" SHOULDER)
*	---	32	YBSD24010	STUD BOLT, 3/4"-16 UNF X 2-3/4" (3/4" SHOULDER)
19	32	---	YNWL20005	WHEEL NUT, 5/8"-18 UNF
*	---	32	YNWL24005	WHEEL NUT, 3/4"-16 UNF GR. 8
20	2	---	YBHH16160	BOLT, 1/2" X 5-1/2" GR. 5
*	---	2	YBHH16165	BOLT, 1/2" X 6" GR. 5
21	2	"	YNNY16005	HEX NUT, NYLON LOCKNUT, 1/2"
*	---	16	YBHH10020	BOLT, 5/16" X 1/2" GR. 5

**NOTE: \* MEANS NOT SHOWN**  
**--- MEANS NOT USED ON THIS MODEL**  
**" MEANS SAME AS PREVIOUS MODEL**

# FIGURE 3

## BEATER DRIVE TRAIN

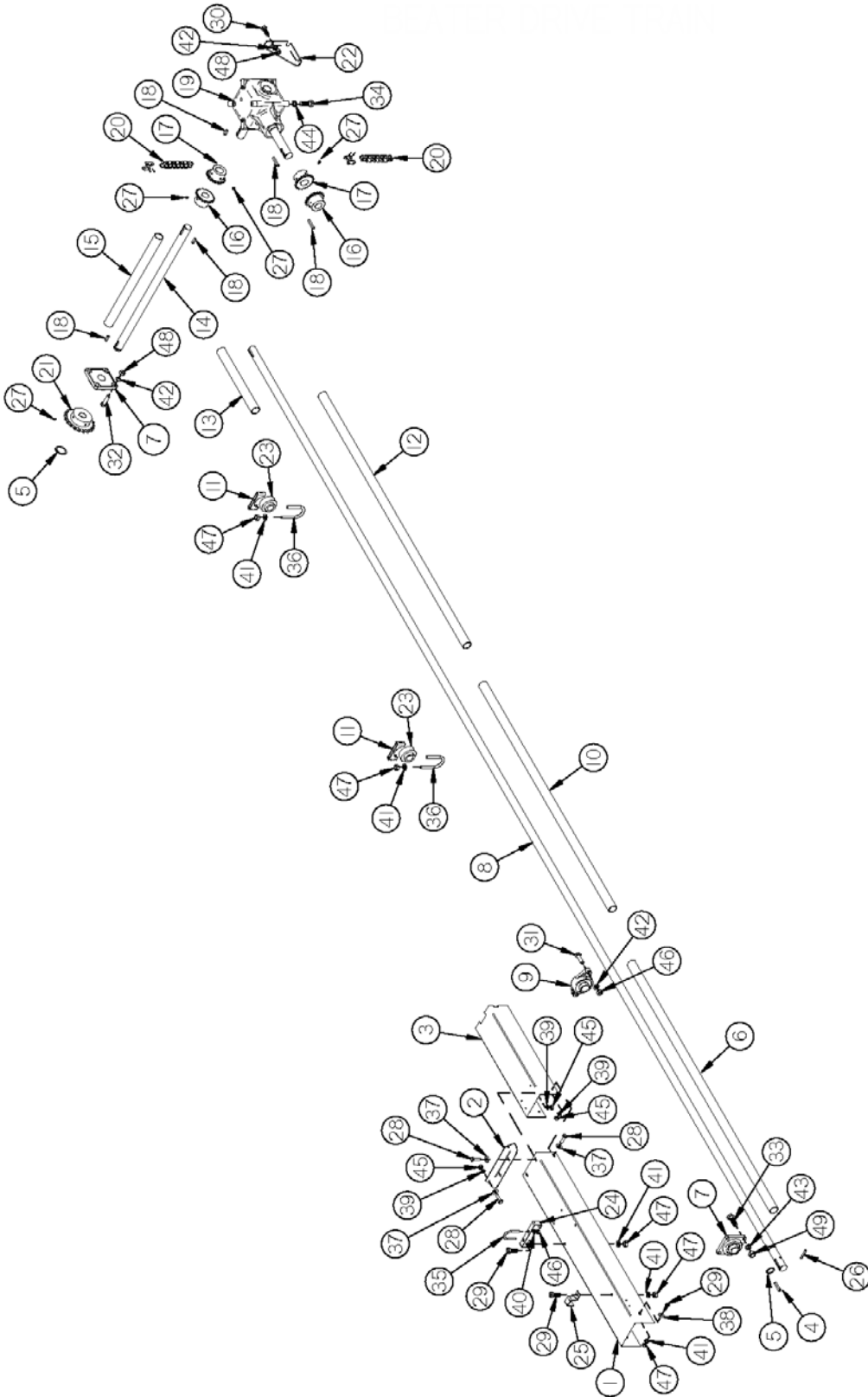

# FIGURE 3

## BEATER DRIVE TRAIN

<u>QTY</u>				
<u>ITEM</u>	<u>HP425</u>	<u>HP550</u>	<u>PART #</u>	<u>DESCRIPTION</u>
1	1	——	42N13	INPUT SHAFT SHIELD
2	1	"	42N14	INPUT SHIELD ANGLE
3	1	"	42N15	INPUT SHIELD BACK
4	1	"	S138	3/8" X 2-3/8" KEY W/ ROUND ENDS
5	2	"	12V62	SNAP RING
6	1	"	42N16	INPUT PVC SHIELD
7	2	"	12V99	BEARING
8	1	"	42N17	INPUT SHAFT
9	1	"	42N18	BEARING
10	1	"	42N19	DRIVE SHAFT CENTER PVC SHIELD
11	2	"	42N137	BEARING SADDLE
12	1	"	42N20	DRIVE SHAFT MIDDLE PVC SHIELD
13	1	"	42N21	DRIVE SHAFT BACK PVC SHIELD
14	1	"	56783	CROSS SHAFT - FOR CLUTCH
15	1	"	42N23	CROSS SHAFT PVC SHIELD
16	2	"	42N24	SPROCKET 50-B-20 1-1/2 BORE
17	2	"	42N25	SPROCKET 50-B-20 1-3/4 BORE
18	5	"	56N174	3/8" X 2" KEY W/ ROUND ENDS (HARDENED)
19	1	"	42N26	GEARBOX
20	2	"	HGV124	CONNECTOR CHAIN #50 X 20 PITCHES
21	1	"	56769	CLUTCH, OVER RUNNING
22	1	"	42N49	GEARBOX GUSSET
23	2	"	42N100	BEARING

**NOTE: \* MEANS NOT SHOWN**  
**—— MEANS NOT USED ON THIS MODEL**  
**" MEANS SAME AS PREVIOUS MODEL**

# FIGURE 3

## BEATER DRIVE TRAIN

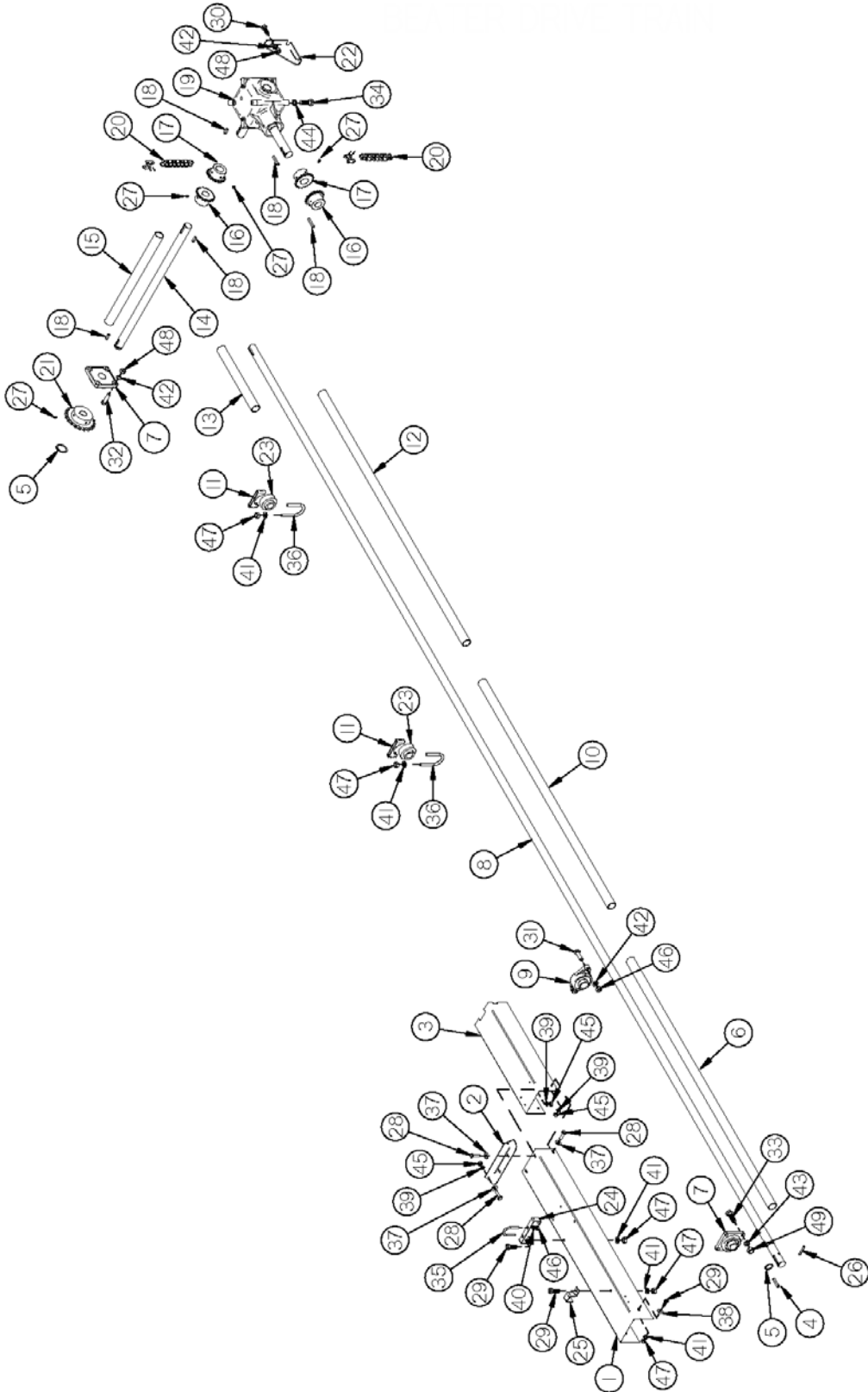

# FIGURE 3

## BEATER DRIVE TRAIN

<u>QTY</u>				
<u>ITEM</u>	<u>HP425</u>	<u>HP550</u>	<u>PART#</u>	<u>DESCRIPTION</u>
24	1	"	42N101	HOSE HOLDER
25	1	"	HE14	SMALL PIPE BRACKET
26	1	"	YPEX12023	EXPANSION PIN, 3/8" X 2-1/2"
27	10	"	YSKP12025	SET SCREW, SOCKET, KNURLED CUP PT, 3/8"-16 X 3/8"
28	6	"	YBHH08010	BOLT, 1/4" X 1" GR. 5
29	5	"	YBHH12010	BOLT, 3/8" X 1" GR. 5
30	2	"	YBHH16045	BOLT, 1/2" X 1-1/4" GR. 5
31	2	"	YBHH16030	BOLT, 1/2" X 1-1/2" GR. 5
32	4	"	YBHH16055	BOLT, 1/2" X 1-3/4" GR. 5
33	4	"	YBHH18015	BOLT, HEX HEAD, 9/16"-12 X 2" GR. 5, ZINC FINISH
34	4	"	YBHH20010	BOLT, 5/8" X 1-1/2" GR. 5
35	1	"	YBPU10007	PIPE U BOLT, 5/16" X 2" ID
36	2	"	YBPU12025	3/8"-16 X 3" PIPE SIZE ZINC PLATED ROUND BEND U-BOLT
37	6	"	YWFL08005	WASHER, FLAT, 1/4" USS
38	2	"	YWFL12005	WASHER, FLAT, 3/8" USS
39	6	"	YWLO08005	WASHER, LOCK, 1/4"
40	2	"	YWLO10005	WASHER, LOCK, 5/16"
41	5	"	YWLO12005	WASHER, LOCK, 3/8"
42	8	"	YWLO16005	WASHER, LOCK, 1/2"
43	4	"	YWLO18005	WASHER, LOCK, 9/16"
44	4	"	YWLO20005	WASHER, LOCK, 5/8"
45	6	"	YNHX08005	HEX NUT, 1/4"-20
46	2	"	YNHX10005	HEX NUT, 5/16"
47	5	"	YNHX12005	HEX NUT, 3/8"-16
48	8	"	YNHX16005	HEX NUT, 1/2"
49	4	"	YNHX18005	HEX NUT, 9/16"-12

**NOTE: " MEANS SAME AS PREVIOUS MODEL**

**FIGURE 4**  
**ENDGATE**

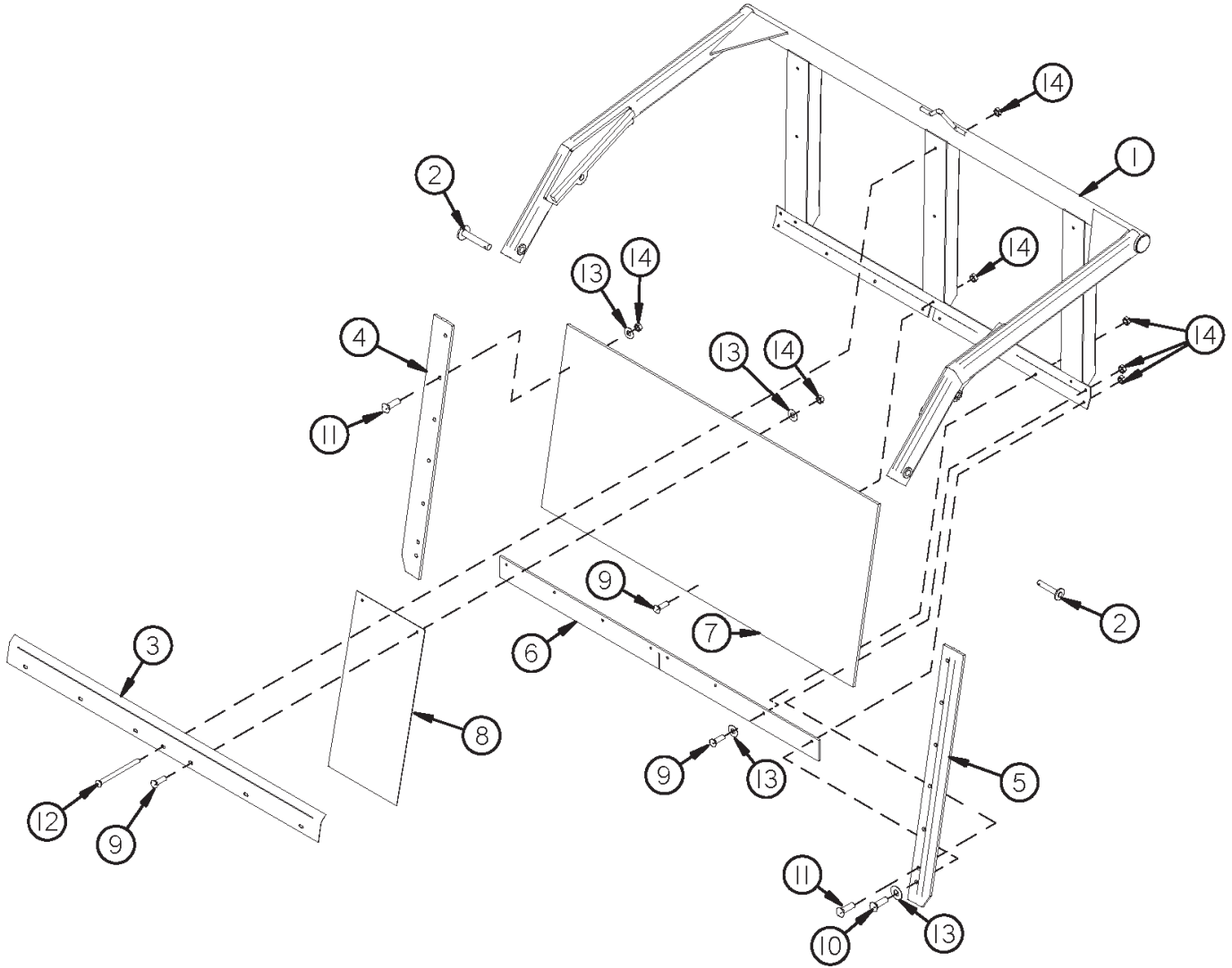



# FIGURE 4 ENDGATE

<u>ITEM</u>	<u>QTY</u>		<u>PART #</u>	<u>DESCRIPTION</u>
	<u>HP425</u>	<u>HP550</u>		
1	1	----	42N28	ENDGATE
*	----	1	55N9	ENDGATE
2	2	----	42N29	HINGE PIN
*	----	2	55N10	HINGE PIN
3	1	----	42N30	ENDGATE POLY HOLDOWN
*	----	1	55N11	ENDGATE POLY HOLDOWN
4	1	----	42N31	ENDGATE RUBBER RIGHT
5	1	----	42N32	ENDGATE RUBBER LEFT
*	----	2	55N13	ENDGATE RUBBER LEFT
6	1	----	42N33	ENDGATE RUBBER
*	----	1	55N14	ENDGATE RUBBER
7	1	----	42N34	ENDGATE POLY
*	----	1	55N15	ENDGATE POLY
8	5	----	42N165	ENDGATE CURTAIN
*	----	5	55N88	ENDGATE CURTAIN
9	13	23	YBCR12010	CARR. BOLT, 3/8" X 1" GR. 5
10	2	"	YBCR12015	CARR. BOLT, 3/8" X 1-1/2" GR. 5
11	12	----	YBCR12030	CARR. BOLT, 3/8" X 1-3/4" GR. 5
12	6	16	YBCR12105	CARR. BOLT, 3/8" X 4-1/2" GR. 5 FULL THREAD
13	22	36	YWFL12005	WASHER, FLAT, 3/8" USS
14	33	41	YNHX12005	HEX NUT, 3/8"-16

**NOTE:** \* MEANS NOT SHOWN  
 ---- MEANS NOT USED ON THIS MODEL  
 " MEANS SAME AS PREVIOUS MODEL

# FIGURE 5

## BEATERS

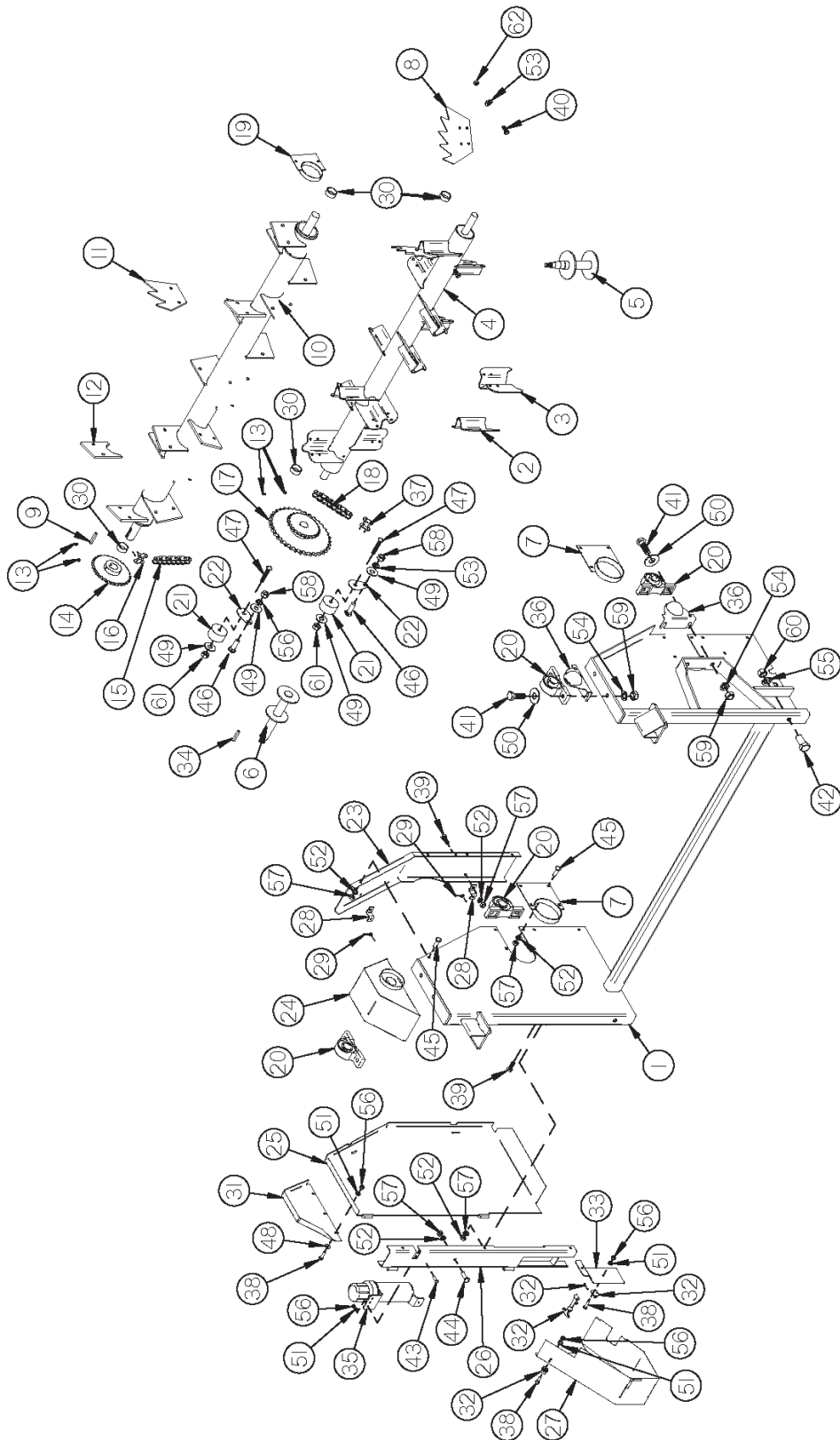

## FIGURE 5

## BEATERS

	<u>QTY</u>			
<u>ITEM</u>	<u>HP425</u>	<u>HP550</u>	<u>PART#</u>	<u>DESCRIPTION</u>
1	1	---	42N35	BEATER PANEL
*	---	1	55N16	BEATER PANEL
2	6	12	42N36	BLADE HOLDER RIGHT
3	6	12	42N37	BLADE HOLDER LEFT
4	1	2	42N38	BEATER
5	1	2	56N69	BEATER STUB SHAFT
6	1	2	42N39	BEATER DRIVE SHAFT
7	2	"	42N40	BEATER SLOT FILLER
8	12	24	23N277	BEATER BLADE
9	1	---	S437	3/8" X 1-1/2" KEY
*	---	1	56N174	3/8" X 2" KEY
10	1	---	42N42	SECOND BEATER
*	---	1	42N38	SECOND BEATER
11	16	---	45N27	SECOND BEATER BLADE
12	16	---	42N147	BLADE HOLDER
13	4	"	YSKP12025	SET SCREW, SOCKET, KNURLED CUP PT, 3/8" - 16 X 3/8"
14	1	---	42N44	SECOND BEATER SPROCKET 60-B-30
*	---	1	16SV213	SECOND BEATER SPROCKET 80-B-23
15	1	---	42N45	SECOND BEATER CHAIN #60 x 98 Pitches
*	---	1	55N17	SECOND BEATER CHAIN #80 x 82 Pitches
16	1	---	D39	CONNECTOR LINK
*	---	1	F157	CONNECTOR LINK
17	1	---	42N46	BEATER SPROCKET #80, 20T To #60,25T (540)
*	---	1	55N19	BEATER SPROCKET #80,36T To #80, 20T (1000)
*	1	---	42N47	BEATER SPROCKET #80,36T To #60,25T (1000)
18	1	---	16SV34	BEATER CHAIN #80 x 79 PITCHES (540)
*	1	"	42N48	BEATER CHAIN #80 x 88 PITCHES (1000)
19	---	1	55N18	SECOND BEATER SLOT FILLER
20	4	"	16SV72	PILLOW BLOCK BEARING
21	2	"	42N50	POLY CHAIN TIGHTENER
22	2	"	42N51	TIGHTENER STOP
23	1	---	42N52	MAIN PANEL RIGHT END
*	---	1	55N20	MAIN PANEL RIGHT END
24	1	---	42N53	SECOND BEATER ANTI-WRAP
25	1	---	42N54	REAR SHIELD
*	---	1	55N21	REAR SHIELD
26	1	---	42N55	SHIELD FILLER
*	---	1	55N22	SHIELD FILLER
27	1	"	42N56	CROSS SHAFT SHIELD

**NOTE: \* MEANS NOT SHOWN**

**--- MEANS NOT USED ON THIS MODEL**

**" MEANS SAME AS PREVIOUS MODEL**

# FIGURE 5

## BEATERS

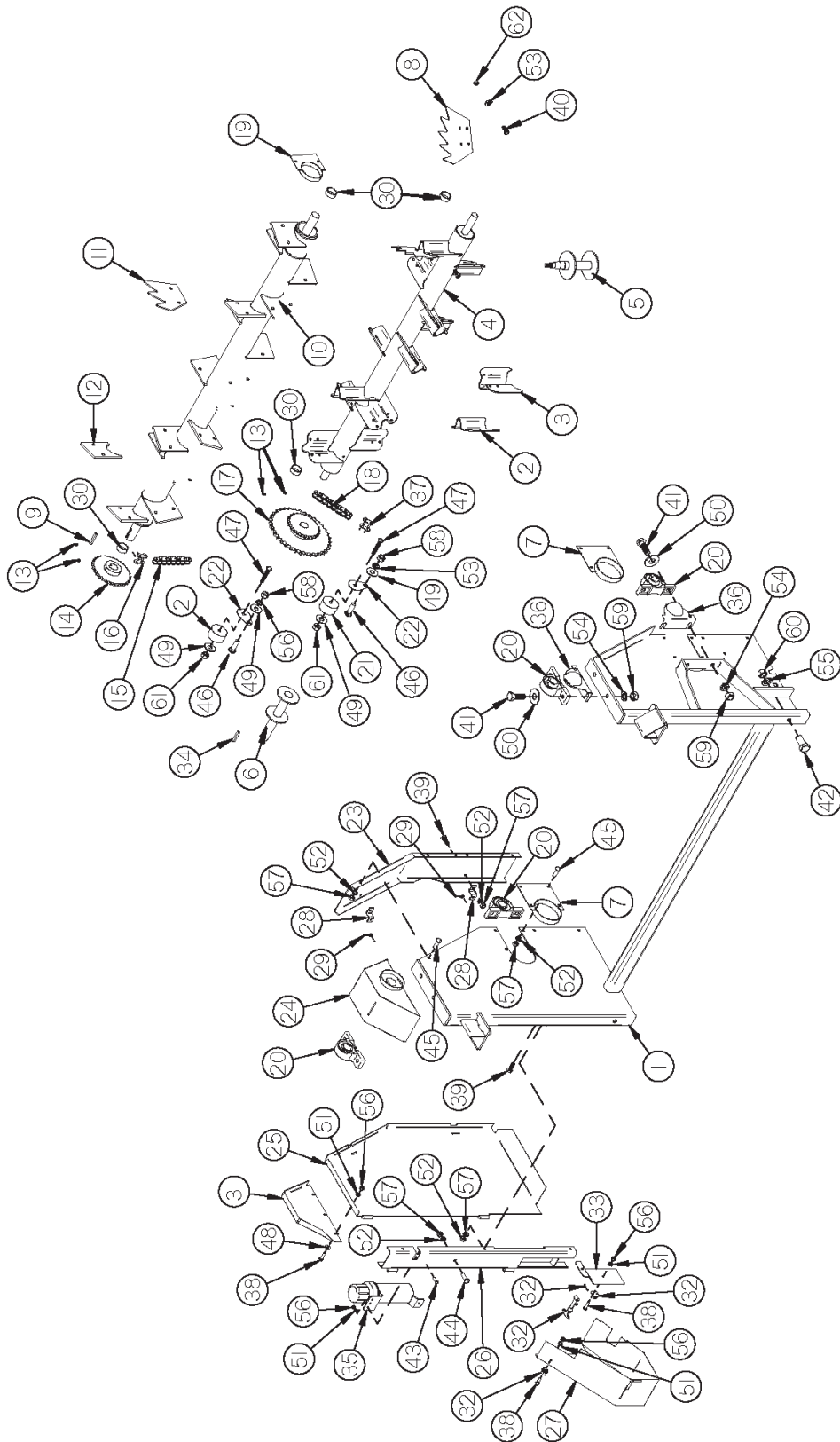

## FIGURE 5

## BEATERS

<u>QTY</u>				
<u>ITEM</u>	<u>HP425</u>	<u>HP550</u>	<u>PART#</u>	<u>DESCRIPTION</u>
28	2	"	F69	SHIELD BRACKET
29	2	"	YPLY08011	LYNCH PIN, 1/4 X 1-9/16 #63-02
30	4	"	42N103	BEATER SPACER
31	1	———	42N104	SECOND BEATER SHIELD
32	1	"	X233	COMPLETE LATCH
33	1	"	42N105	BACK STAKE FILLER
34	1	"	42N141	KEY 3/8" x 2-1/4" W/ ROUND ENDS
35	1	"	S522	MANUAL HOLDER
36	2	———	42N142	STUB SHAFT SHIELD
37	1	"	F157	#80 CONNECTOR LINK
38	5	2	YBHH08010	BOLT, 1/4" X 1" GR. 5
39	5	6	YBHH12010	BOLT, 3/8" X 1" GR. 5
40	80	96	YBHH16045	BOLT, 1/2" X 1-1/4" GR. 5
41	8	"	YBHH18015	BOLT, HEX HEAD, 9/16"-12 X 2" GR. 5, ZINC
42	2	"	YBHH24010	BOLT, 3/4" X 1-1/2" GR. 5
43	3	"	YSTM08004	SLOTTED TRUSS HEAD ZINC MACHINE SCREW, 1/4"-20 x 3/4"
44	1	"	YBCR12065	CARR. BOLT, 3/8" X 3/4" GR. 5
45	11	12	YBCR12010	CARR. BOLT, 3/8" X 1" GR. 5
46	2	"	YBCR16015	CARR. BOLT, 1/2" X 1-1/4" GR. 5
47	2	"	YBCR16035	CARR. BOLT, 1/2" X 2-3/4" GR. 5
48	3	———	YWFL08005	WASHER, FLAT, 1/4" USS
49	4	"	YWFL16005	WASHER, FLAT, 1/2" USS
50	8	"	YWFL18005	WASHER, FLAT, 9/16" USS
51	8	5	YWLO08005	WASHER, LOCK, 1/4"
52	17	19	YWLO12005	WASHER, LOCK, 3/8"
53	82	98	YWLO16005	WASHER, LOCK, 1/2"
54	8	"	YWLO18005	WASHER, LOCK, 9/16"
55	2	"	YWLO24005	WASHER, LOCK, 3/4"
56	8	5	YNHX08005	HEX NUT, 1/4"-20
57	17	19	YNHX12005	HEX NUT, 3/8"-16
58	2	"	YNHX16005	HEX NUT, 1/2"
59	8	"	YNHX18005	HEX NUT, 9/16"-12
60	2	"	YNHX24005	HEX NUT, 3/4"-10 PLATED
61	2	"	YNRL16005	HEX NUT, REVERSIBLE-SIDE LOCK, 1/2"-13
62	80	96	YNTL16005	HEX NUT, TOP LOCK, 1/2"-13

**NOTE: \* MEANS NOT SHOWN**

**——— MEANS NOT USED ON THIS MODEL**

**" MEANS SAME AS PREVIOUS MODEL**

# FIGURE 6

## PUSHER

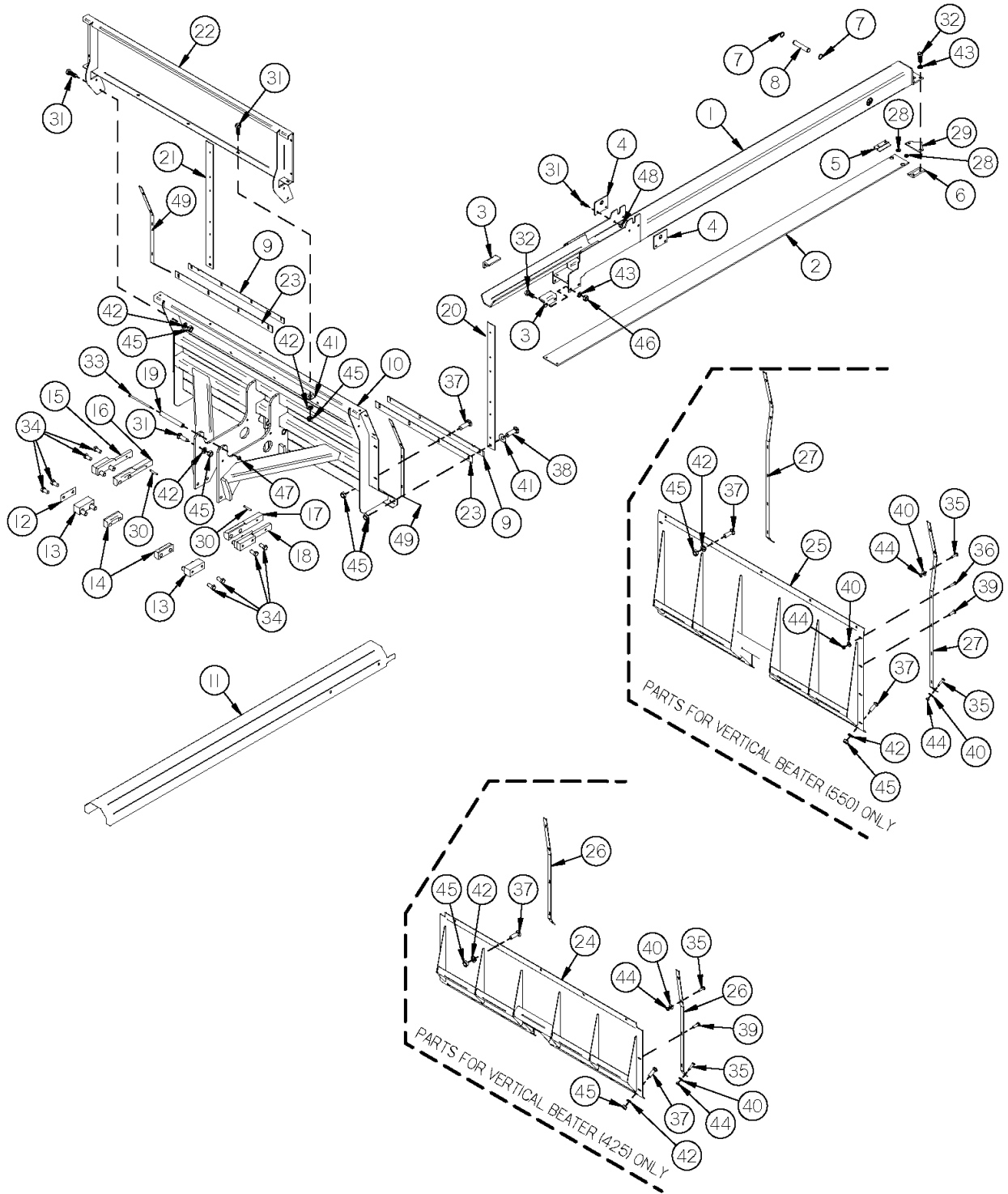

## FIGURE 6

### PUSHER

<u>ITEM</u>	<u>QTY</u>		<u>PART #</u>	<u>DESCRIPTION</u>
	<u>HP425</u>	<u>HP550</u>		
1	1	—	42N74	MOVEABLE FLOOR TUBE
*	—	1	55N44	MOVEABLE FLOOR TUBE
2	1	—	42N149	PUSHER TUBING SLIDE
*	—	1	55N85	PUSHER TUBING SLIDE
3	2	—	42N76	PUSHER TUBE FRONT GUIDE
*	—	2	55N46	PUSHER TUBE FRONT GUIDE
4	2	—	42N77	CYLINDER RETAINER
*	—	2	55N47	CYLINDER RETAINER
5	1	—	42N78	END CAP CLAMP RIGHT
*	—	1	55N48	END CAP CLAMP RIGHT
6	1	—	42N79	END CAP CLAMP LEFT
*	—	1	55N49	END CAP CLAMP LEFT
7	2	—	3G21	SNAP RING 1"
*	—	2	F73	SNAP RING 1-1/4"
8	1	—	42N80	REAR CYLINDER PIN
*	—	1	55N50	REAR CYLINDER PIN
9	2	—	42N81	PUSHER WIPER
*	—	2	55N81	PUSHER WIPER
10	1	—	42N83	PUSHER
*	—	1	55N26	PUSHER
11	1	—	42N84	CYLINDER SHIELD
*	—	1	55N51	CYLINDER SHIELD
12	A/R	A/R	42N114	PUSHER SHIM (AR)
13	2	—	42N85	POLY BLOCK SPACER
*	—	2	55N52	POLY BLOCK SPACER
14	2	—	42N86	PUSHER POLY SLIDE
*	—	2	55N53	PUSHER POLY SLIDE
15	1	—	42N87	POLY BLOCK SPACER RIGHT
*	—	1	55N54	POLY BLOCK SPACER RIGHT
16	1	—	42N88	PUSHER POLY SLIDE RIGHT
*	—	1	55N55	PUSHER POLY SLIDE RIGHT
17	1	—	42N89	PUSHER POLY SLIDE LEFT
*	—	1	55N56	PUSHER POLY SLIDE LEFT
18	1	—	42N90	POLY BLOCK SPACER LEFT
*	—	1	55N57	POLY BLOCK SPACER LEFT
19	1	—	42N91	PUSHER SPACER
*	—	1	55N59	PUSHER SPACER

**NOTE: \* MEANS NOT SHOWN**

**— MEANS NOT USED ON THIS MODEL**

**" MEANS SAME AS PREVIOUS MODEL**

**A/R MEANS AS REQUIRED**

# FIGURE 6

# PUSHER

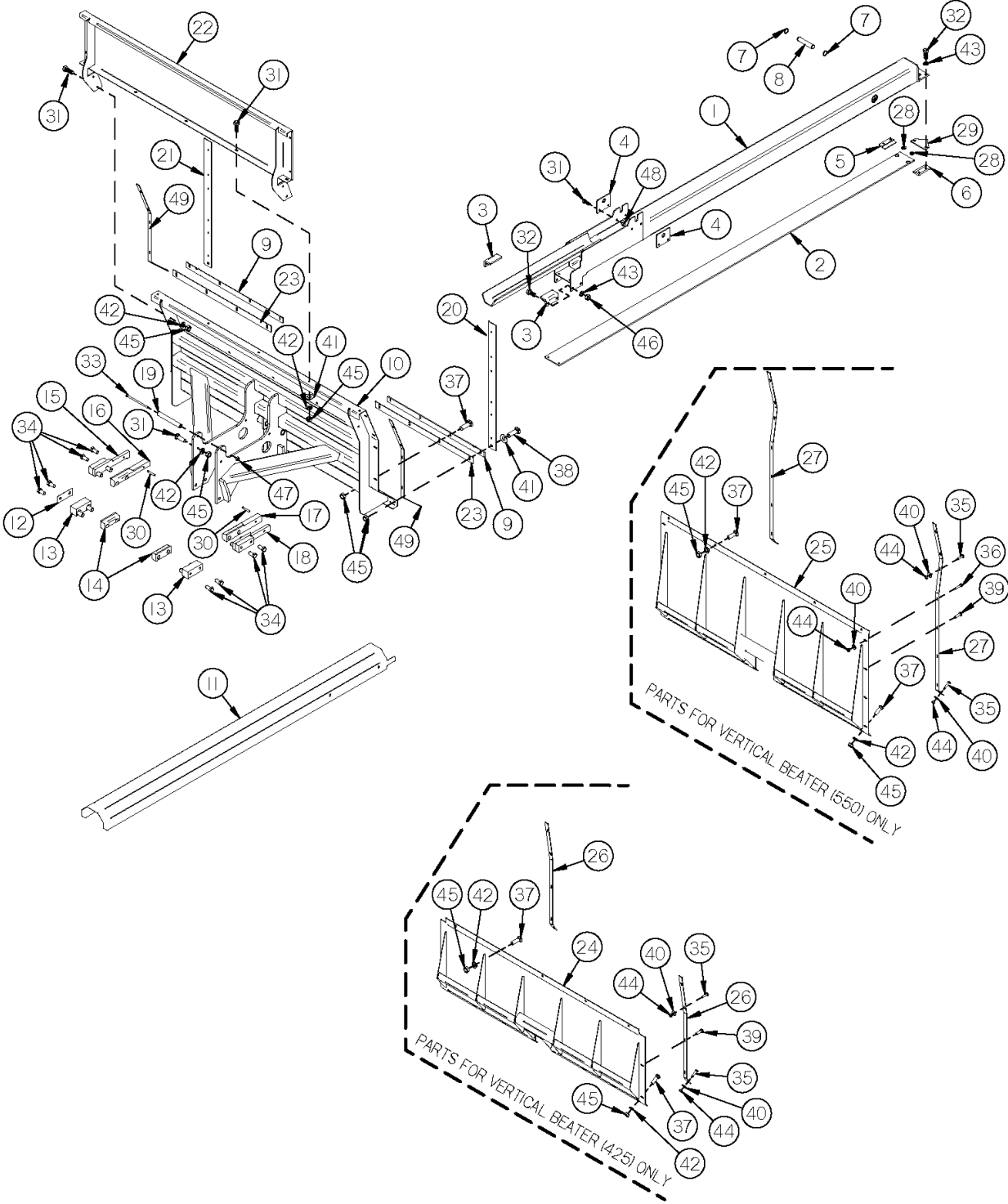



# FIGURE 6

## PUSHER

<u>ITEM</u>	<u>QTY</u>		<u>PART #</u>	<u>DESCRIPTION</u>
	<u>HP425</u>	<u>HP550</u>		
20	1	——	42N92	PUSHER RUBBER LEFT
*	——	1	55N27	PUSHER RUBBER LEFT
21	1	——	42N93	PUSHER RUBBER RIGHT
*	——	1	55N28	PUSHER RUBBER RIGHT
22	1	“	42N94	PUSHER EXTENSION
23	2	——	42N139	PUSHER BOTTOM RUBBER
*	——	2	55N83	PUSHER BOTTOM RUBBER
24	1	——	HGV115	FLAT PUSHER FACE
25	——	1	HGV113	FLAT PUSHER FACE
26	2	——	HGV116	FLAT PUSHER SEAL STRAP
27	——	2	HGV114	FLAT PUSHER SEAL STRAP
28	2	“	42N150	POLY SPACER
*	1	——	42N151	SCRAPER
29	——	1	55N86	SCRAPER
30	2	——	YPEX12020	EXPANSION PIN, 3/8" X 2"
*	——	2	YPEX12023	EXPANSION PIN, 3/8" X 2-1/2"
31	17	“	YBHH12010	BOLT, 3/8" X 1" GR. 5
32	8	“	YBHH16045	BOLT, 1/2" X 1-1/4" GR. 5
33	1	——	YBHH16185	BOLT, 1/2" X 9" GR. 5
*	——	1	YBHH16200	BOLT, 1/2" X 10" GR. 5
34	8	“	YBHH20015	BOLT, 5/8" X 1-1/4" GR. 5
35	6	8	YBCR08005	CARR. BOLT, 1/4" X 1"
36	——	2	YBCR08010	CARR. BOLT, 1/4" X 1-1/2" GR. 5
37	19	“	YBCR12010	CARR. BOLT, 3/8" X 1" GR. 5
38	2	“	YBCR12015	CARR. BOLT, 3/8" X 1-1/2" GR. 5
39	4	6	YSHW10010	5/16"-18 x 1-1/4" HEX WASHER SLOT TYPE F ZINC THREAD CUTTING SCREW
40	6	10	YWFL08005	WASHER, FLAT, 1/4" USS
41	7	“	YWFL12005	WASHER, FLAT, 3/8" USS
42	26	“	YWLO12005	WASHER, LOCK, 3/8"
43	8	“	YWLO16005	WASHER, LOCK, 1/2"
44	6	10	YNHX08005	HEX NUT, 1/4"-20
45	34	“	YNHX12005	HEX NUT, 3/8"-16
46	4	“	YNHX16005	HEX NUT, 1/2"
47	1	“	YNNY16005	HEX NUT, NYLON LOCKNUT, 1/2"
48	4	“	YNRL12005	HEX NUT, REVERSIBLE-SIDE LOCK, 3/8"-16
49	2	——	42N82	PUSHER RUBBER STRAP
	——	2	55N26	PUSHER RUBBER STRAP

**NOTE: \* MEANS NOT SHOWN**

—— MEANS NOT USED ON THIS MODEL

“ MEANS SAME AS PREVIOUS MODEL

**FIGURE 7**  
**PUSHER & ENDGATE HYD. COMPONENTS**

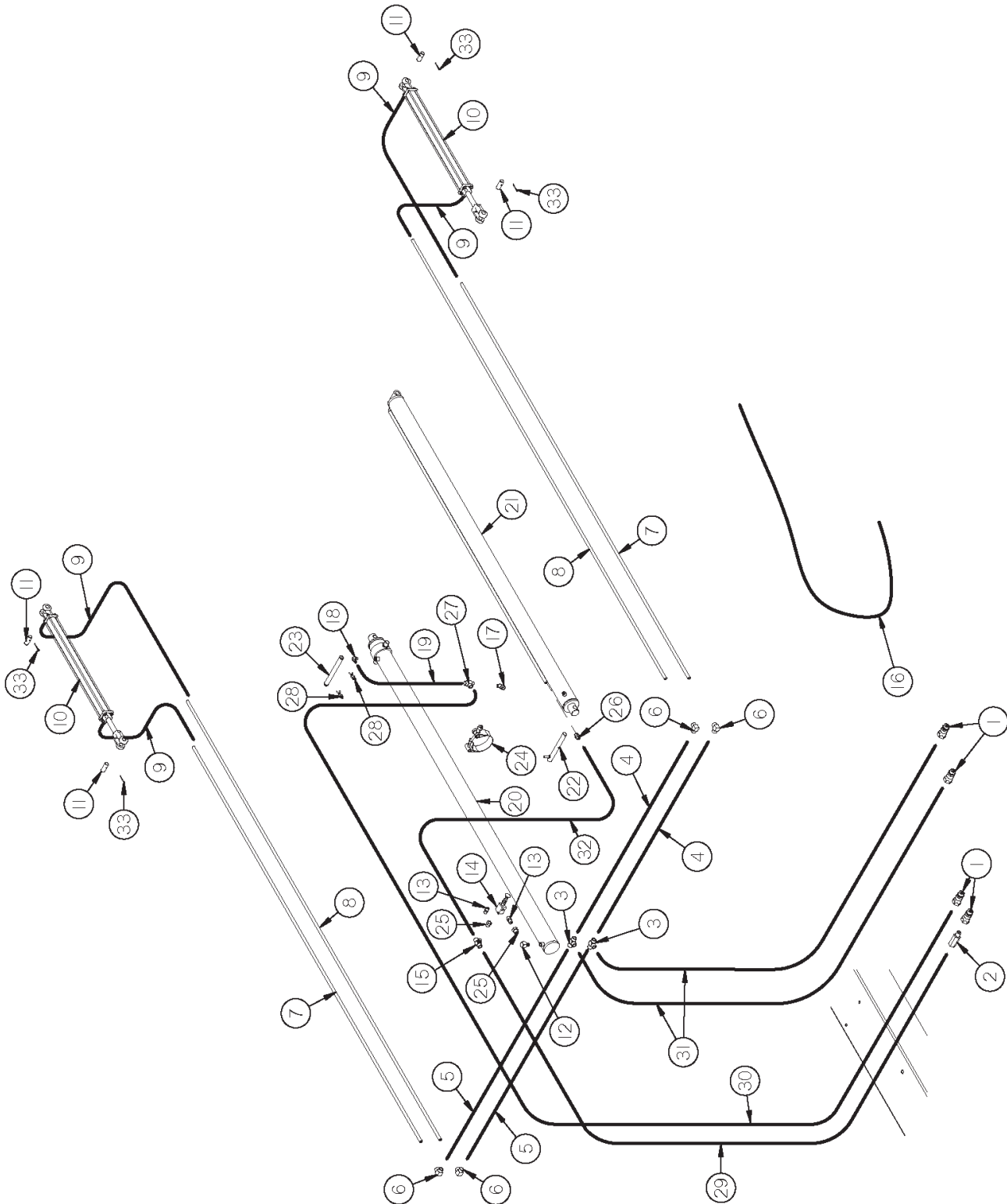

## FIGURE 7

### PUSHER & ENDGATE HYD. COMPONENTS

#### QTY

<u>ITEM</u>	<u>HP425</u>	<u>HP550</u>	<u>PART #</u>	<u>DESCRIPTION</u>
1	4	"	DWM205	QUICK COUPLER MALE
2	1	"	57735	.078 RESTRICTOR/CHECK VALVE
3	2	"	BFR74	3/8" TEE
4	2	"	46N40	HYDRAULIC HOSE 3/8" x 46" (3/8" MPX x 3/8" MP)
5	2	"	BFR287	HYDRAULIC HOSE 3/8" x 36" (3/8" MPX x 3/8" MP)
6	4	"	HE59	3/8" ELBOW
7	2	---	42N59	END GATE HYDRAULIC LINE SHORT
*	---	2	55N23	END GATE HYDRAULIC LINE SHORT
8	2	---	42N60	END GATE HYRDAULIC LINE LONG
*	---	2	55N24	END GATE HYRDAULIC LINE LONG
9	4	"	12V19	HYDRAULIC HOSE 3/8" x 24" (3/8 FP x 3/8 MPX 90°)
10	2	"	56002	HYDRAULIC CYLINDER (2 x 20)
11	4	"	56N141	CYLINDER PIN
12	1	---	23N234	3/8" STREET ELBOW
*	---	1	HE58	1/2" STREET ELBOW
13	1	2	16SV351	3/8" NIPPLE NUT
14	1	"	16SV339	SEQUENCE VALVE
15	1	---	WM146	3/8" MALE, FEMALE TEE
*	---	1	DF8	1/2" TEE
16	1	"	42N64	HOSE SHIELD (1-1/2" ID x 73")
17	1	---	42N67	3/8" UNION ADAPTER 45°
*	---	1	55N65	1/2" UNION ADAPTER 45°
18	1	---	DWM110	3/8" 90° UNION ADAPTER
*	---	1	HE58	1/2" STREET ELBOW
19	1	---	42N68	HYDRAULIC HOSE 3/8" x 20-1/2" (3/8" MP 3/8"90° MPX)

**NOTE: \* MEANS NOT SHOWN**

**--- MEANS NOT USED ON THIS MODEL**

**" MEANS SAME AS PREVIOUS MODEL**

**FIGURE 7**  
**PUSHER & ENDGATE HYD. COMPONENTS**

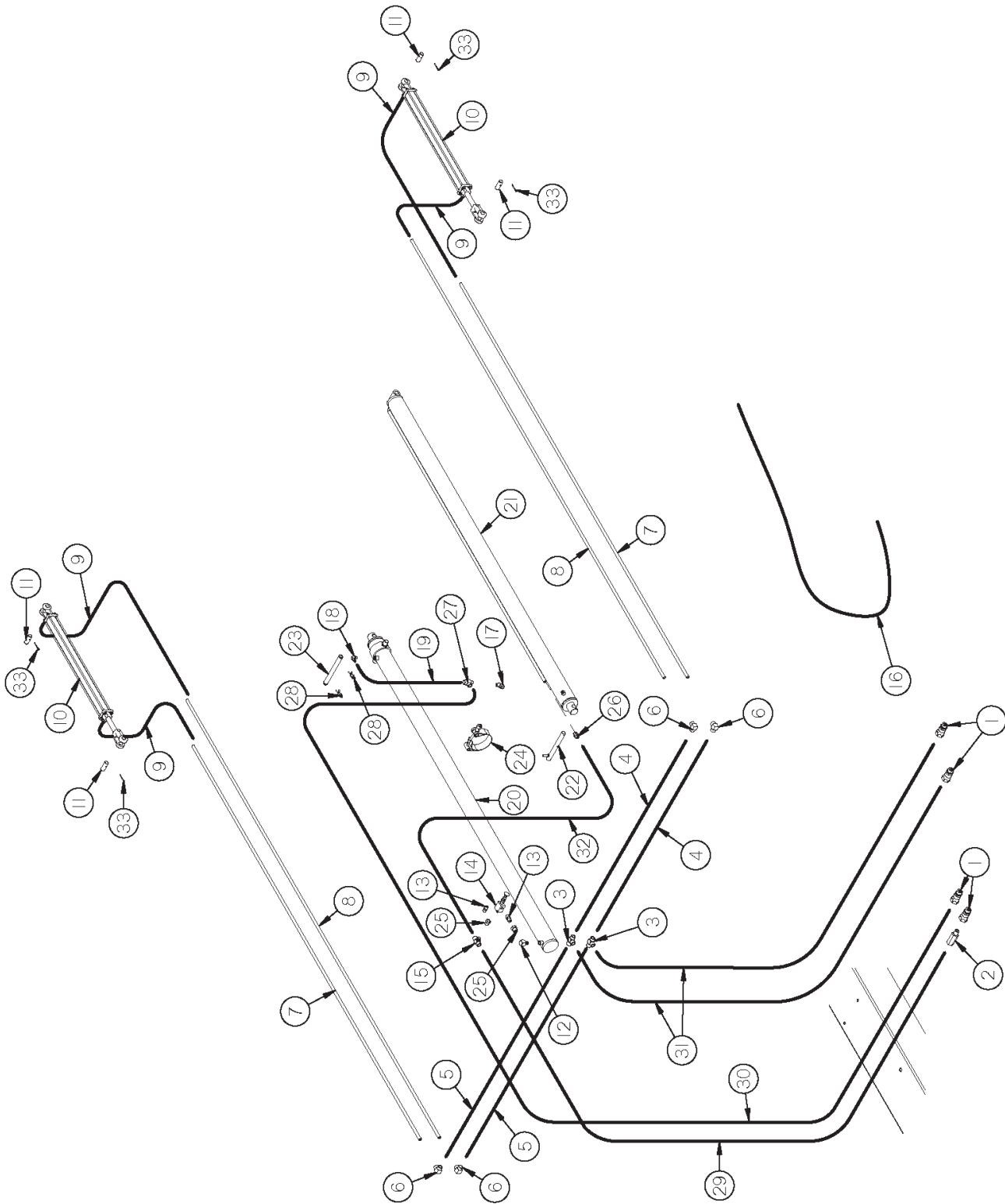

## FIGURE 7

### PUSHER & ENDGATE HYD. COMPONENTS

<u>QTY</u>				
<u>ITEM</u>	<u>HP425</u>	<u>HP550</u>	<u>PART #</u>	<u>DESCRIPTION</u>
*	---	1	16SV143	HYDRAULIC HOSE 1/2" x 19" (1/2" MP 1/2" MPX)
20	1	---	42N69	HYDRAULIC CYLINDER (3-1/2" x 90") GIMBAL MOUNT
*	---	1	55N32	HYDRAULIC CYLINDER (4-1/2" x 90") GIMBAL MOUNT
21	1	---	42N70	HYDRAULIC CYLINDER (3-1/2" x 90") TRUNNION MOUNT
*	---	1	55N33	HYDRAULIC CYLINDER (4-1/2" x 90") TRUNNION MOUNT
22	1	---	42N71	CYLINDER PIN
*	---	1	55N34	CYLINDER PIN
23	1	---	42N72	PUSHER CYLINDER PIN
*	---	1	55N35	PUSHER CYLINDER PIN
24	1	---	12V70	HOSE CLAMP SAE # 88
*	---	1	55N66	HOSE CLAMP SAE #104
25	---	2	JB82	1/2" TO 3/8" BUSHING
26	1	---	DWM233	3/8" UNION ADAPTER
*	---	1	MA12	1/2" MALE ADAPTER UNION
27	1	---	23N116	3/8" SERVICE TEE
*	---	1	WM139	1/2" MALE - FEMALE TEE
28	2	"	T144	CYLINDER CLIP PIN
29	1	---	HGV168	HYDRAULIC HOSE 3/8" X 186" (101HY-8-6 X 101HY-6-6)
*	---	1	HGV165	HYDRAULIC HOSE 1/2" X 186" (101HY-8-8 X 101HY-8-8)
30	1	---	HGV169	HYDRAULIC HOSE 3/8" X 260" (101HY-8-6 X 101HY-6-6)
*	---	1	HGV166	HYDRAULIC HOSE 1/2" X 260" (101HY-8-8 X 101HY-8-8)
31	2	"	HGV167	HYDRAULIC HOSE 3/8" X 157" (101HY-8-6 X 101HY-6-6)
32	1	---	42N66	HYDRAULIC HOSE 3/8" x 76" (3/8"MP Both Ends)
*	---	1	55N30	HYDRAULIC HOSE 1/2" x 76" (1/2"MP Both Ends)
33	4	"	YPCT07005	COTTER PIN, 7/32" X 2 "

**NOTE: \* MEANS NOT SHOWN**

**--- MEANS NOT USED ON THIS MODEL**

**" MEANS SAME AS PREVIOUS MODEL**

# FIGURE 8

## ENDGATE CYLINDER

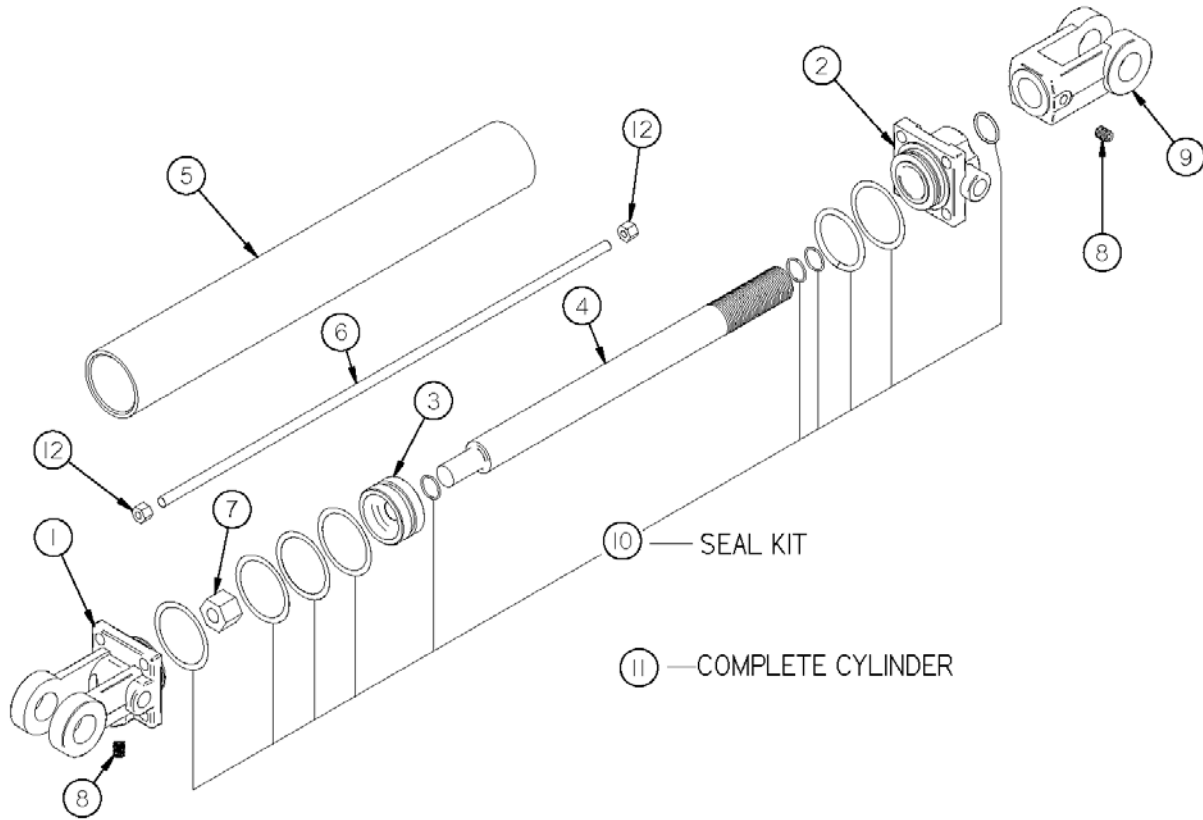

# FIGURE 8

## ENDGATE CYLINDER

<u>QTY</u>				
<u>ITEM</u>	<u>HP425</u>	<u>HP550</u>	<u>PART #</u>	<u>DESCRIPTION</u>
1	1	"	23N142A	CLEVIS CAP
2	1	"	56174	ROD CAP
3	1	"	56180	PISTON
4	1	"	45N42	ROD
5	1	"	45N43	CYLINDER TUBE
6	4	"	45N44	TIE ROD
7	1	"	23N148	PISTON NUT
8	2	"	23N149	PLUG
9	1	"	23N150A	ROD CLEVIS
10	1	"	56187	SEAL KIT
11	1	"	56002	HYDRAULIC CYLINDER
12	8	"	YNHX12005	HEX NUT, 3/8"-16

**NOTE: " MEANS SAME AS PREVIOUS MODEL**

**FIGURE 9**  
**HYDRAULIC PUSHER CYLINDER**

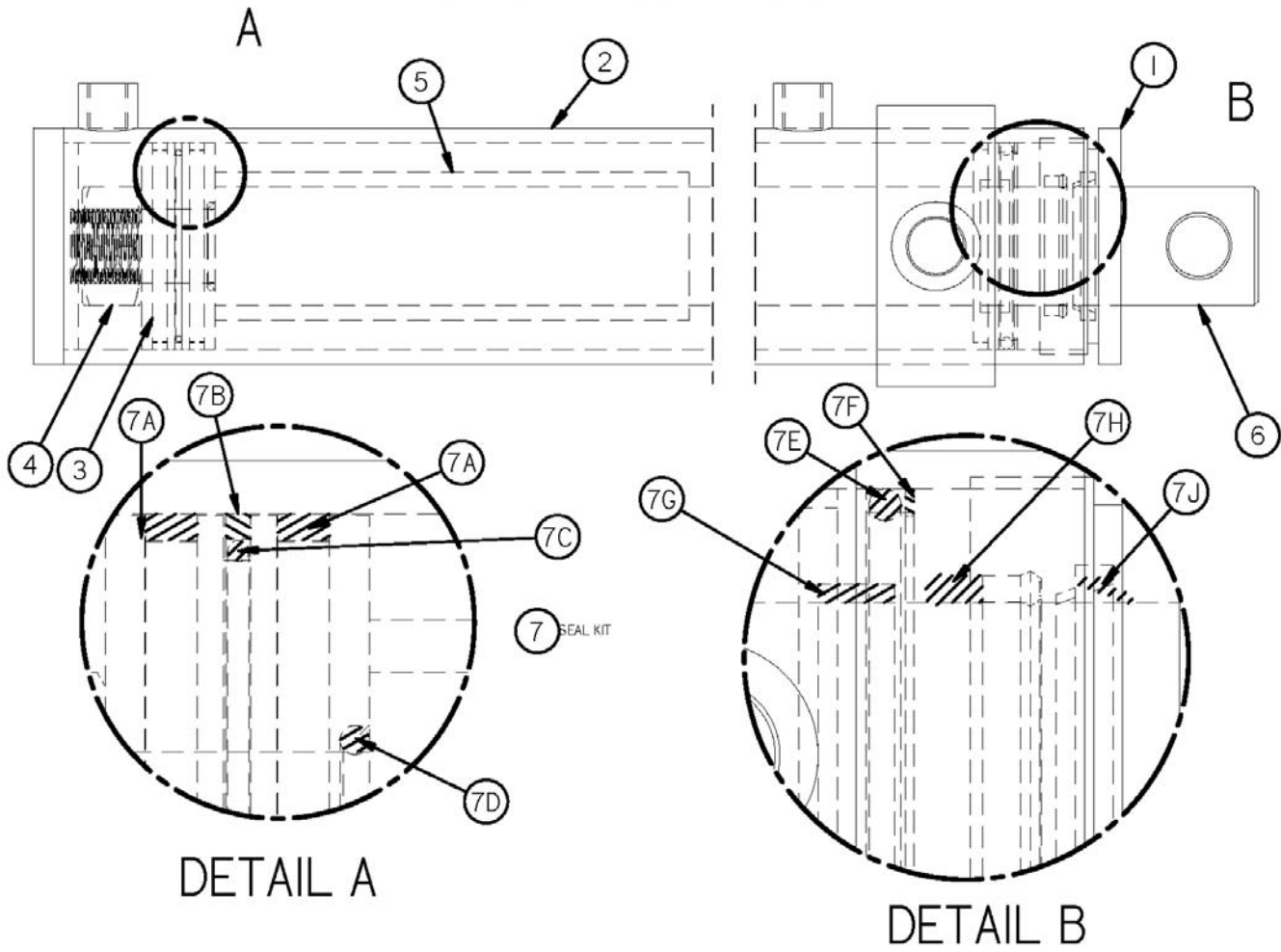



## FIGURE 9

### HYDRAULIC PUSHER CYLINDER

	<u>QTY</u>			
<u>ITEM</u>	<u>HP425</u>	<u>HP550</u>	<u>PART #</u>	<u>DESCRIPTION</u>
1	1	---	42N106	INTERNAL HEAD
*	---	1	55N36	INTERNAL HEAD
2	1	---	42N107	BARREL ASSM (TOP CYL)
*	---	1	55N37	BARREL ASSM (TOP CYL)
*	1	---	42N108	BARREL ASSM (BOTTOM CYL)
*	---	1	55N38	BARREL ASSM (BOTTOM CYL)
3	1	---	42N109	PISTON
*	---	1	55N39	PISTON
4	1	---	42N110	LOCKNUT
*	---	1	55N40	LOCKNUT
5	1	---	42N111	SPACER
*	---	1	55N41	SPACER
6	1	---	42N112	ROD
*	---	1	55N42	ROD
7	1	---	42N113	SEAL KIT (INC ITEMS 7A THRU 7J)
*	---	1	55N43	SEAL KIT (INC ITEMS 7A THRU 7J)
7A	2	"	"	WEAR RING
7B	1	"	"	P
7C	1	"	"	O-RING
7D	1	"	"	O-RING
7E	1	"	"	O-RING
7F	1	"	"	BACK-UP RING
7G	1	"	"	WEAR RING
7H	1	"	"	LOADED U-CUP
7J	1	"	"	ROD WIPER
*	1	---	42N69	COMP. CYL. - TOP
*	---	1	55N32	COMP. CYL. - TOP
*	1	---	42N70	COMP. CYL. - BOTTOM
*	---	1	55N33	COMP. CYL. - BOTTOM

**NOTE: \* MEANS NOT SHOWN**

**--- MEANS NOT USED ON THIS MODEL**

**" MEANS SAME AS PREVIOUS MODEL**

**FIGURE 10**  
**BEATER GEARBOX**

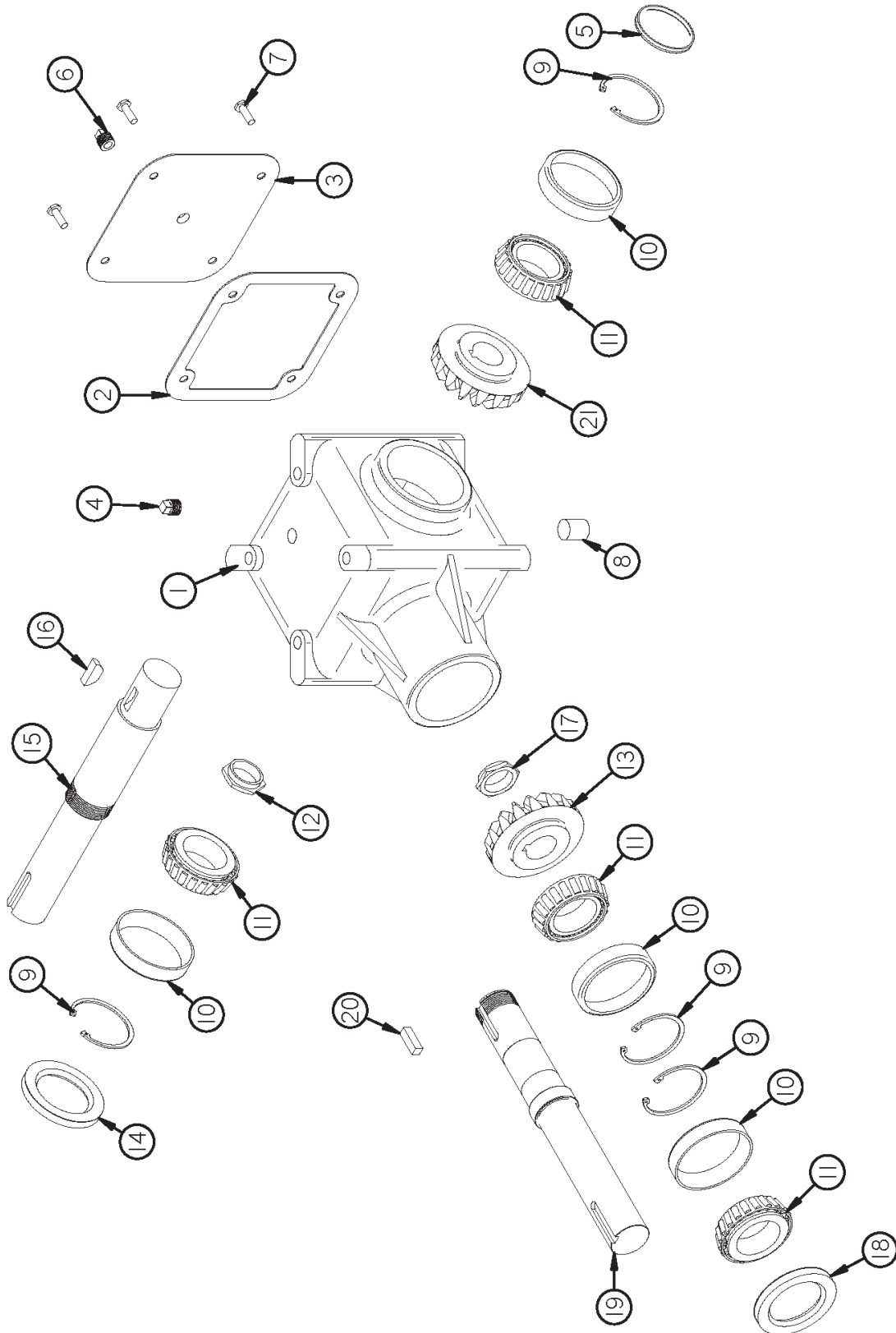

# FIGURE 10

## BEATER GEARBOX

<u>QTY</u>				
<u>ITEM</u>	<u>HP425</u>	<u>HP550</u>	<u>PART #</u>	<u>DESCRIPTION</u>
1	1	"	G125	HOUSING
2	1	"	G138	GASKET
3	1	"	G126	COVER
4	1	"	G144	PLUG 3/8" - VENT
5	1	"	G140	CAP
6	1	"	G65	PLUG 3/8" - NPT
7	4	"	YBHH10132	BOLT, 5/16" X 5/8"
8	1	"	G145	3/8" PLUG
9	4	"	G130	SNAP RING
10	4	"	G128	BEARING CUP #25520
11	4	"	G129	BEARING #25581
12	1	"	G132	STAKE NUT
13	1	"	G142	BEVEL GEAR 22 TEETH
14	1	"	G136	SEAL - OUTPUT
15	1	"	42N57	OUTPUT SHAFT
16	1	"	G61	"E" 1210 WOODRUFF KEY
17	1	"	G133	STAKE NUT
18	1	"	G137	SEAL - INPUT
19	1	"	42N58	INPUT SHAFT
20	1	"	G139	KEY 3/8" x 1-1/2" HARDENED
21	1	"	G127	BEVEL GEAR 33 TOOTH
*	1	"	42N26	COMPLETE GEARBOX

**NOTE: \* MEANS NOT SHOWN**

**" MEANS SAME AS PREVIOUS MODEL**

**FIGURE 11**  
**VERTICAL BEATERS FRAME ASSEMBLY (425)**

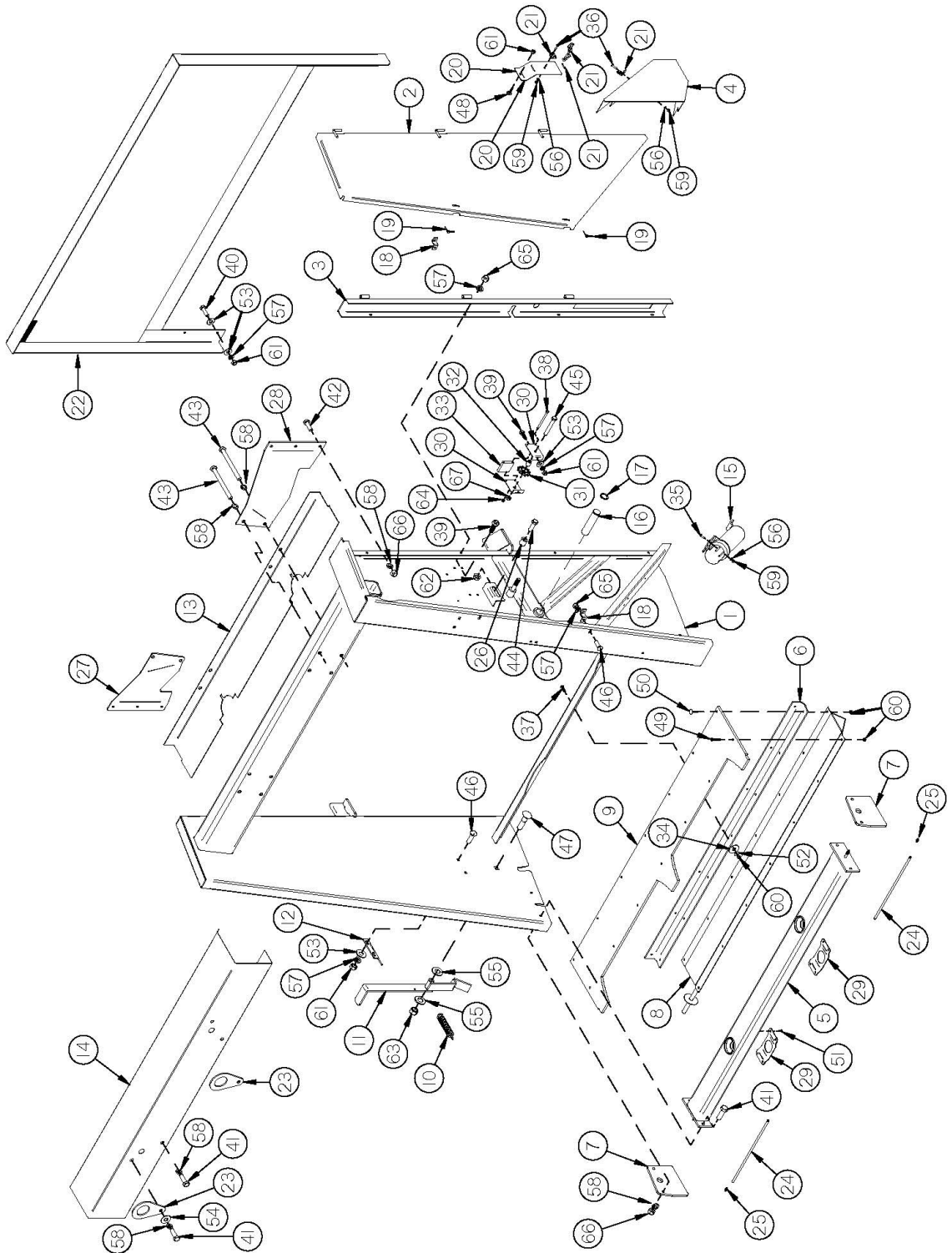

# FIGURE 11

## VERTICAL BEATERS FRAME ASSEMBLY (425)

<u>ITEM</u>	<u>HP425VB</u>	<u>PART #</u>	<u>DESCRIPTION</u>
1	1	HGV54	FRAME
2	1	HGV3	REAR SHIELD
3	1	HGV5	SHIELD FILLER
4	1	HGV7	CROSS SHAFT SHIELD
5	1	HGV8	BEATER BOTTOM MOUNT
6	1	HGV9	PAN HINGE
7	2	HGV10	LEG
8	1	HGV11	PAN BOTTOM
9	1	HGV12	PAN
10	1	K103	SPRING
11	1	HGV13	PAN HANDLE
12	1	HGV14	PAN HANDLE STOP
13	1	HGV56	GEARBOX BOTTOM SHIELD SUPERIOR
14	1	HGV57	GEARBOX TOP SHIELD SUPERIOR
15	1	S522	MANUAL HOLDER
16	1	HGV18	SPROCKET IDLER SHAFT
17	1	12V62	SNAP RING
18	2	F69	SHIELD BRACKET
19	2	YPLY08011	LYNCH PIN, 1/4 X 1-9/16 #63-02
20	1	42N105	BACK STAKE FILLER
21	1	X233	COMPLETE LATCH
22	1	HGV49	STONE GUARD
23	2	HGV50	LIFTING EYE
24	2	HGV51	GREASE LINE
25	2	56694	GREASE FITTING
26	1	16SV44	TIGHTENER SPACER
27	1	HGV134	MAIN PANEL BRACE LEFT
28	1	HGV133	MAIN PANEL BRACE RIGHT
29	2	26VB56	HUB CAP RETAINER
30	2	HGV100	IDLER BRACKET
31	1	16SV328	SPROCKET 80-C-12 W/BEARING
32	1	60533	TIGHTNER SPACER
33	1	HGV109	CHAIN POLY BLOCK
*	1	HGV117	COMPLETE IDLER ASSEMBLY
34	7	S304	TIGHTENER WASHER
35	3	YBHH08100	BOLT, 1/4" X 3/4" GR. 5

**NOTE: \* MEANS NOT SHOWN**

**FIGURE 11**  
**VERTICAL BEATERS FRAME ASSEMBLY (425)**

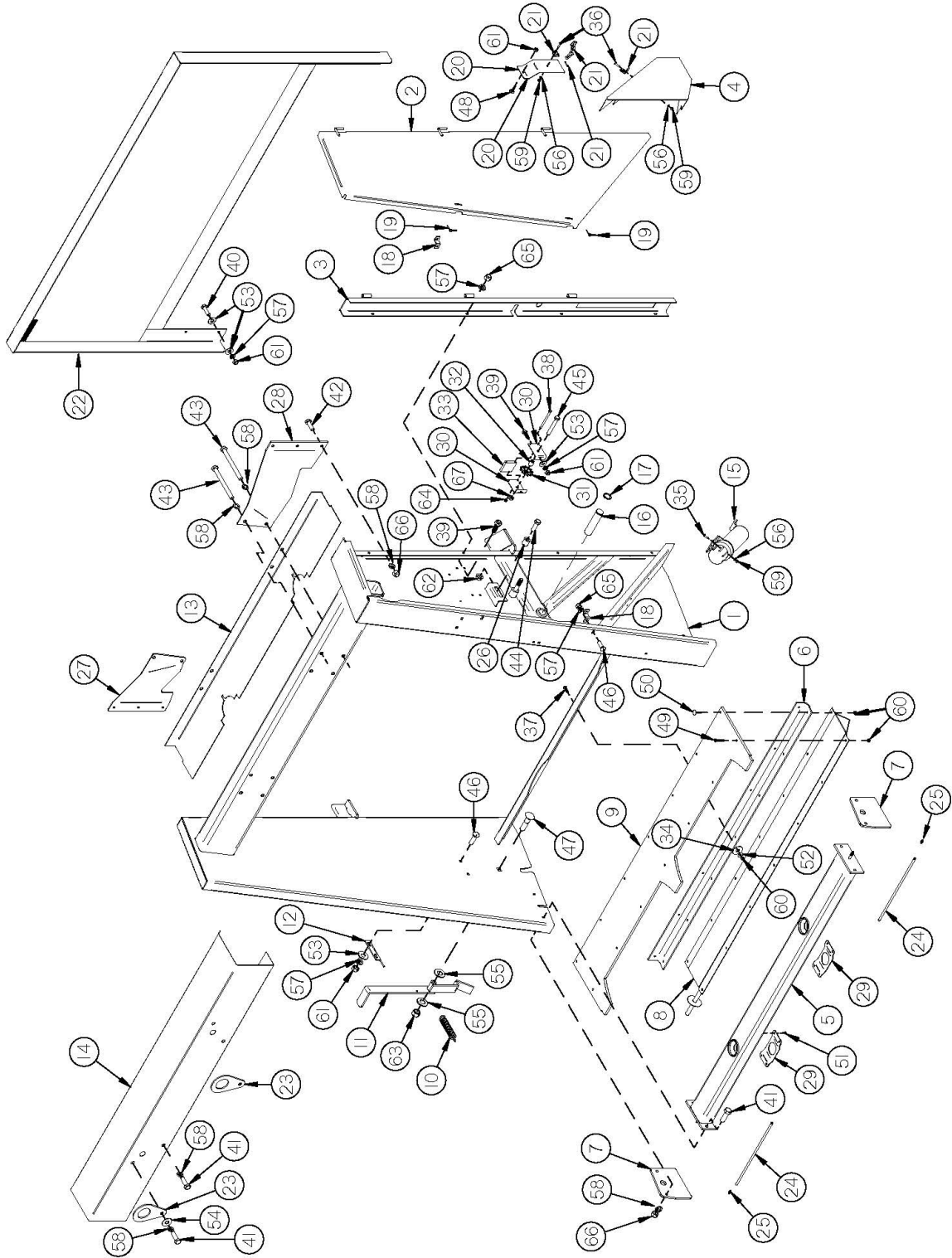

# FIGURE 11

## VERTICAL BEATERS FRAME ASSEMBLY (425)

<u>ITEM</u>	<u>HP425VB</u>	<u>PART #</u>	<u>DESCRIPTION</u>
36	2	YBHH08010	BOLT, 1/4" X 1" GR. 5
37	7	YBHH10010	BOLT, 5/16" X 1" GR. 5
38	2	YBHH10125	BOLT, 5/16" X 4-1/2" GR. 5
39	6	YBHH12010	BOLT, 3/8" X 1" GR. 5
40	4	YBHH12035	BOLT, 3/8" X 1-1/4" GR. 5
41	8	YBHH16030	BOLT, 1/2" X 1-1/2" GR. 5
42	6	YBHH16047	BOLT, 1/2" X 1-1/4" GR. 5 (3/4" MAX THREAD)
43	8	YBHH16160	BOLT, 1/2" X 5-1/2" GR. 5
44	1	YBHH24035	BOLT, 3/4" X 2-1/4" GR. 5
45	1	YBHH24080	BOLT, 3/4" X 5" GR. 5
46	4	YBCR12010	CARR. BOLT, 3/8" X 1" GR. 5
47	1	YBCR24005	CARR. BOLT, 3/4" X 3-1/2" GR. 5
48	1	YBPL12010	#3 FLAT HEAD PLOW BOLT, 3/8"-16 X 1-1/4" GR. 5, ZINC
49	7	YSFS10005	FLAT HEAD SOCKET CAP SCREW, 5/16" X 1"
50	7	YBSB10005	STEP BOLT, 5/16"-18 X 1-1/2"
51	8	YSDR08005	SELF DRILLING SCREW, 1/4"-14 X 1"
52	7	YWFL10005	WASHER, FLAT, 5/16" USS
53	12	YWFL12005	WASHER, FLAT, 3/8" USS
54	2	YWFL16005	WASHER, FLAT, 1/2" USS
55	2	16SV49	WASHER
56	5	YWLO08005	WASHER, LOCK, 1/4"
57	14	YWLO12005	WASHER, LOCK, 3/8"
58	22	YWLO16005	WASHER, LOCK, 1/2"
59	5	YNHX08005	HEX NUT, 1/4"-20
60	21	YNHX10005	HEX NUT, 5/16"
61	9	YNHX12005	HEX NUT, 3/8"-16
62	1	YNFG24005	HEX NUT, FLANGED-LOCK, 3/4"-10
63	1	YNRL24005	HEX NUT, REVERSIBLE-SIDE LOCK, 3/4"-10
64	2	YNL10005	HEX NUT, TOP LOCK, 5/16"-18
65	7	YNL12005	HEX NUT, TOP LOCK, 3/8"-16
66	10	YNL16005	HEX NUT, TOP LOCK, 1/2"-13
67	1	YNL24005	HEX NUT, TOP LOCK, 3/4"-10

**FIGURE 12**  
**VERTICAL BEATERS FRAME ASSEMBLY (550)**

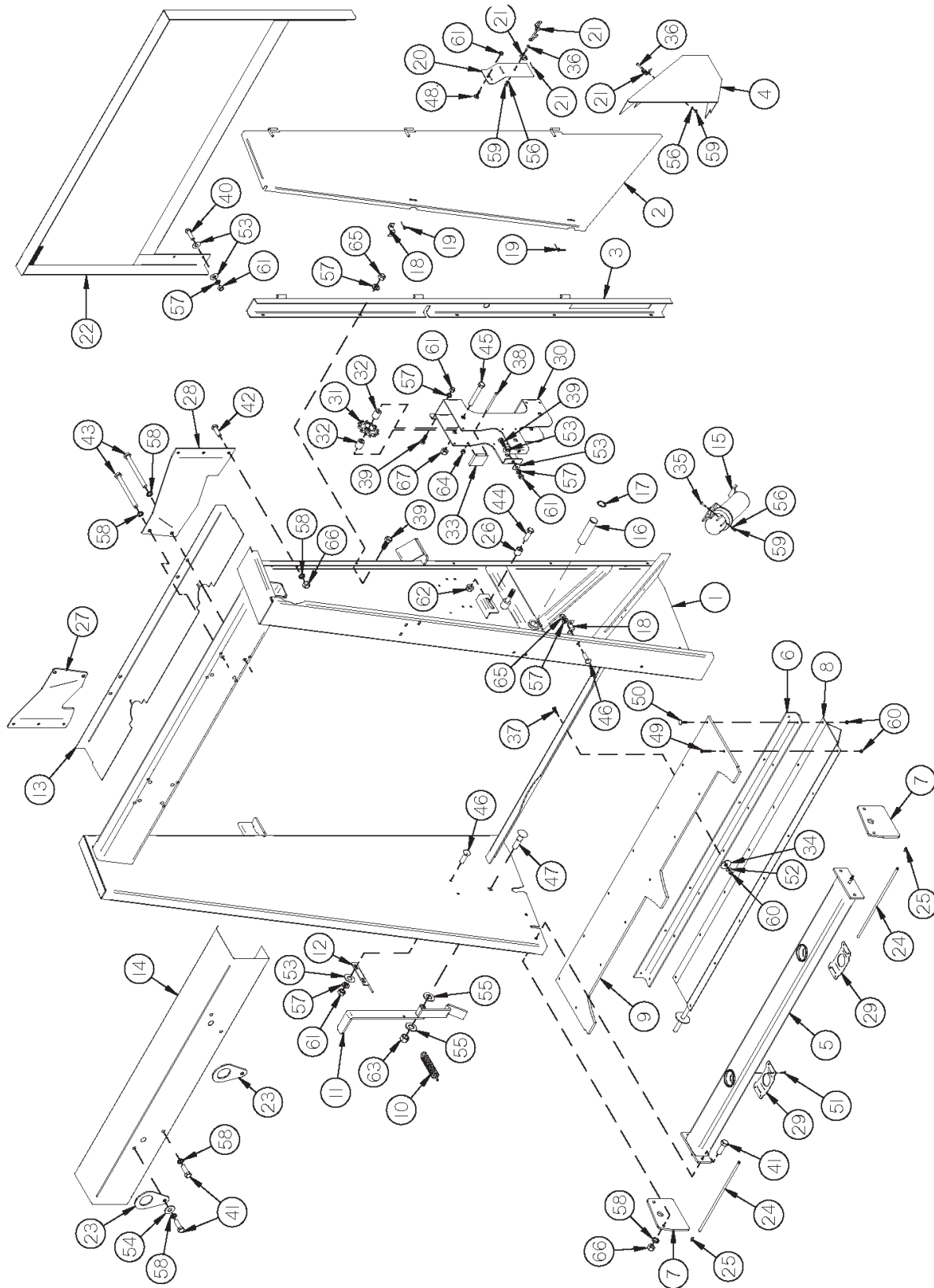



## FIGURE 12

### VERTICAL BEATERS FRAME ASSEMBLY (550)

<u>ITEM</u>	<u>HP550VB</u>	<u>PART #</u>	<u>DESCRIPTION</u>
1	1	HGV55	FRAME
2	1	HGV4	REAR SHIELD
3	1	HGV6	SHIELD FILLER
4	1	HGV7	CROSS SHAFT SHIELD
5	1	HGV8	BEATER BOTTOM MOUNT
6	1	HGV9	PAN HINGE
7	2	HGV10	LEG
8	1	HGV11	PAN BOTTOM
9	1	HGV12	PAN
10	1	K103	SPRING
11	1	HGV13	PAN HANDLE
12	1	HGV14	PAN HANDLE STOP
13	1	HGV56	GEARBOX BOTTOM SHIELD SUPERIOR
14	1	HGV57	GEARBOX TOP SHIELD SUPERIOR
15	1	S522	MANUAL HOLDER
16	1	HGV18	SPROCKET IDLER SHAFT
17	1	12V62	SNAP RING
18	2	F69	SHIELD BRACKET
19	2	YPLY08011	LYNCH PIN, 1/4 X 1-9/16 #63-02
20	1	42N105	BACK STAKE FILLER
21	1	X233	COMPLETE LATCH
22	1	HGV49	STONE GUARD
23	2	HGV50	LIFTING EYE
24	2	HGV51	GREASE LINE
25	2	56694	GREASE FITTING
26	1	16SV44	TIGHTENER SPACER
27	1	HGV107	MAIN PANEL BRACE LEFT
28	1	HGV106	MAIN PANEL BRACE RIGHT
29	2	26VB56	HUB CAP RETAINER
30	1	HGV131	IDLER BRACKET
31	3	16SV328	SPROCKET 80-C-12 W/BEARING
32	2	HGV111	SPROCKCET SPACER
33	3	HGV109	CHAIN POLY BLOCK
34	7	S304	TIGHTENER WASHER
35	3	YBHH08100	BOLT, 1/4" X 3/4" GR. 5

**FIGURE 12**  
**VERTICAL BEATERS FRAME ASSEMBLY (550)**

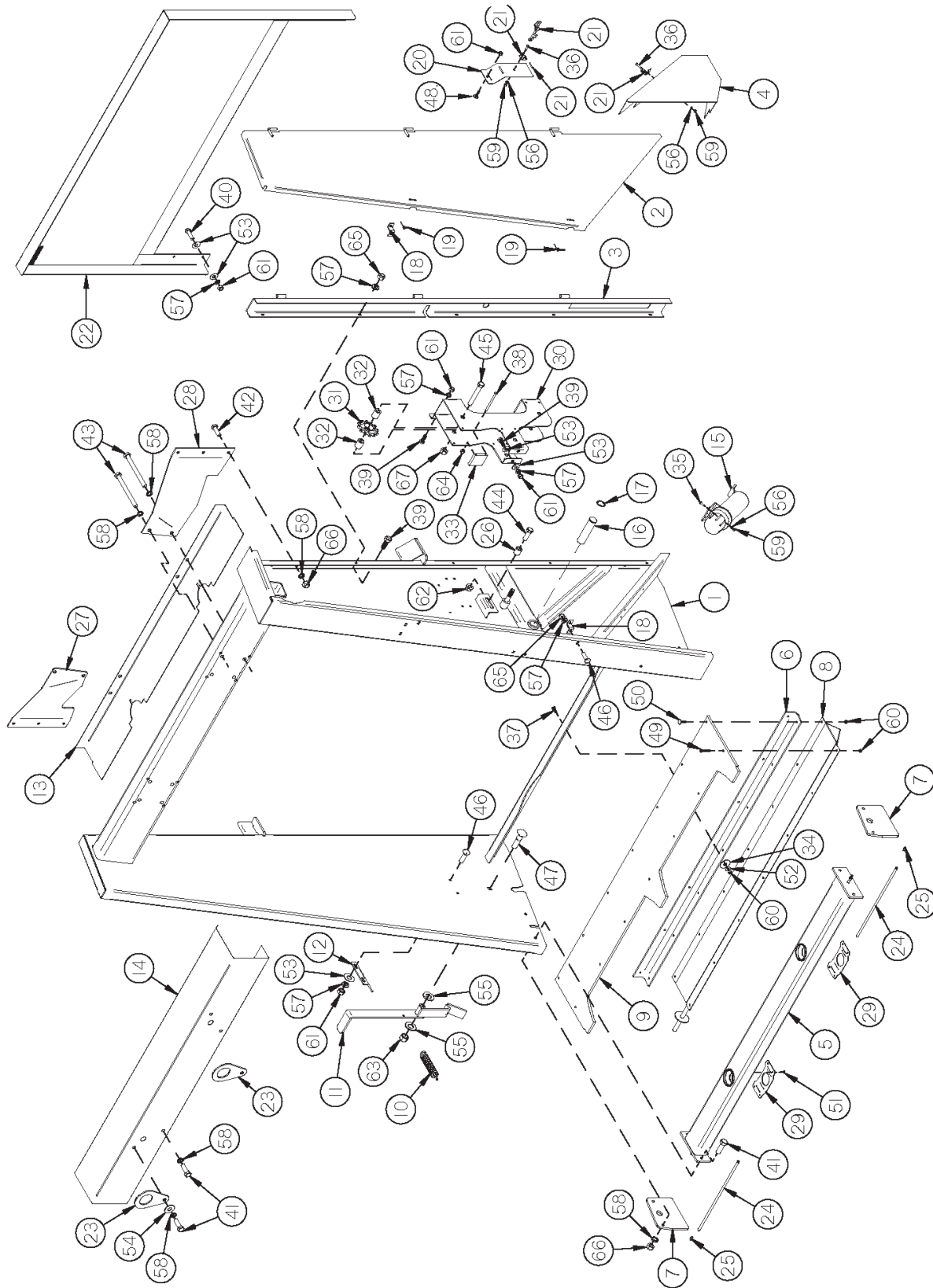

## FIGURE 12

### VERTICAL BEATERS FRAME ASSEMBLY (550)

<u>ITEM</u>	<u>HP550VB</u>	<u>PART #</u>	<u>DESCRIPTION</u>
36	2	YBHH08010	BOLT, 1/4" X 1" GR. 5
37	7	YBHH10010	BOLT, 5/16" X 1" GR. 5
38	6	YBHH10125	BOLT, 5/16" X 4-1/2" GR. 5
39	9	YBHH12010	BOLT, 3/8" X 1" GR. 5
40	4	YBHH12035	BOLT, 3/8" X 1-1/4" GR. 5
41	8	YBHH16030	BOLT, 1/2" X 1-1/2" GR. 5
42	6	YBHH16047	BOLT, 1/2" X 1-1/4" GR. 5 (3/4" MAX THREAD)
43	8	YBHH16160	BOLT, 1/2" X 5-1/2" GR. 5
44	1	YBHH24035	BOLT, 3/4" X 2-1/4" GR. 5
45	3	YBHH24080	BOLT, 3/4" X 5" GR. 5
46	4	YBCR12010	CARR. BOLT, 3/8" X 1" GR. 5
47	1	YBCR24005	CARR. BOLT, 3/4" X 3-1/2" GR. 5
48	1	YBPL12010	#3 FLAT HEAD PLOW BOLT, 3/8"-16 X 1-1/4" GR. 5, ZINC
49	7	YSFS10005	FLAT HEAD SOCKET CAP SCREW, 5/16" X 1"
50	7	YBSB10005	STEP BOLT, 5/16"-18 X 1-1/2"
51	8	YSDR08005	SELF DRILLING SCREW, 1/4"-14 X 1"
52	7	YWFL10005	WASHER, FLAT, 5/16" USS
53	14	YWFL12005	WASHER, FLAT, 3/8" USS
54	2	YWFL16005	WASHER, FLAT, 1/2" USS
55	2	16SV49	WASHER
56	5	YWLO08005	WASHER, 1/4"
57	17	YWLO12005	WASHER, LOCK, 3/8"
58	22	YWLO16005	WASHER, LOCK, 1/2"
59	5	YNHX08005	HEX NUT, 1/4"-20
60	21	YNHX10005	HEX NUT, 5/16"
61	11	YNHX12005	HEX NUT, 3/8"-16
62	1	YNFG24005	HEX NUT, FLANGED-LOCK, 3/4"-10
63	1	YNRL24005	HEX NUT, REVERSIBLE-SIDE LOCK, 3/4"-10
64	6	YNTL10005	HEX NUT, TOP LOCK, 5/16"-18
65	7	YNTL12005	HEX NUT, TOP LOCK, 3/8"-16
66	10	YNTL16005	HEX NUT, TOP LOCK, 1/2"-13
67	3	YNTL24005	HEX NUT, TOP LOCK, 3/4"-10

**FIGURE 13**  
**VERTICAL BEATERS DRIVE TRAIN**



# FIGURE 13

## VERTICAL BEATERS DRIVE TRAIN

<u>QTY</u>				
<u>ITEM</u>	<u>HP425VB</u>	<u>HP550VB</u>	<u>PART #</u>	<u>DESCRIPTION</u>
1	1	---	HGV118	BEATER LEFT HAND
*	---	1	HGV119	BEATER LEFT HAND
2	1	---	HGV120	BEATER RIGHT HAND
*	---	1	HGV121	BEATER RIGHT HAND
3	21	28	HGV122	BEATER BLADE LEFT
4	21	28	HGV123	BEATER BLADE RIGHT
5	2	"	HGV27	SEAL
6	2	"	B5	BEARING CONE
7	2	"	B5A	BEARING CUP
8	2	"	3G18	BEARING CUP
9	2	"	3G7	BEARING CONE
10	2	"	17G144	HUB CAP
11	2	"	56N174	3/8" X 2" SQUARE KEY W/ ROUND ENDS (HARD)
12	1	"	HGV58	GEARBOX LEFT SUPERIOR
13	2	"	26VB37	GEARBOX CONNECTOR
14	6	"	42N25	SPROCKET 50-B-20 1-3/4 BORE
15	3	"	HGV124	CONNECTOR CHAIN #50 X 20 PITCHES
*	3	"	D118	CONNECTOR LINK #50
16	1	"	HGV59	GEARBOX CROSS SHAFT SUPERIOR
17	1	"	HGV60	GEARBOX RIGHT SUPERIOR
18	1	"	HGV61	GEARBOX DRIVE SHAFT SUPERIOR
19	1	"	HGV41	BEARING
20	1	"	HGV25	SPROCKET 80-B-20 1-3/4 BORE
21	1	---	HGV126	80H X 98 PITCHS ROLLER CHAIN
*	---	1	HGV125	80H CHAIN X 137 PITCH CONN LINK /OFF SET
*	1	"	F157	CONNECTOR LINK #80
*	A/R	A/R	HGV163	80H HALF LINK CHAIN
22	2	"	12V52	BEARING
23	2	"	12V77	IDLER SPROCKET W/BEARING (80-A-12)
24	1	"	HGV36	BEATER TIGHTENER
25	2	"	42N100/42N164	BEARING FHSR208-24/BEARING CSB-208-24G
*	2	"	16SV375	SHIM .130 <b>(ONLY USED WITH 42N164 BEARING)</b>
26	1	---	HGV38	SPROCKET 80-A-20 TO 80-A-20
*	---	1	HGV37	SPROCKET 80-A-36 TO 80-A-20
27	1	---	HGV128	80H X 109 PITCH ASSEMBLED
*	---	1	HGV127	80H CHAIN X 117 PITCHS HEAVY CHAIN

**NOTE: \* MEANS NOT SHOWN**  
**---** MEANS NOT USED ON THIS MODEL  
**"** MEANS SAME AS PREVIOUS MODEL  
**A/R:** AS REQUIRED

# FIGURE 13

## VERTICAL BEATERS DRIVE TRAIN



# FIGURE 13

## VERTICAL BEATERS DRIVE TRAIN

### QTY

<u>ITEM</u>	<u>HP425VB</u>	<u>HP550VB</u>	<u>PART #</u>	<u>DESCRIPTION</u>
*	1	"	F157	CONNECTOR LINK #80H
28	1	"	10R14	SPRING
29	1	"	HGV30	SPACER
30	1	"	60533	TIGHTENER SPACER
31	1	"	HGV42	TIGHTENER
32	2	"	56N160	SPRING HOLDER
33	1	"	ST36	SPRING
34	8	"	26VB57	FAN BLADE
35	2	"	HGV129	BEATER RUBBER SEAL
36	2	"	HGV130	BEATER SEAL CAP
37	2	"	HGV102	BEATER STUB SHAFT
38	7	"	PB136	KEY 3/8" X 2" SQUARE W/ ROUND ENDS
39	2	"	YPCT05020	COTTER PIN, 5/32" X 1-1/2"
40	16	"	YSKP12025	SET SCREW, SOCKET, KNURLED CUP PT, 3/8"- 16 X 3/8"
41	12	"	YBHH08100	BOLT, 1/4" X 3/4" GR. 5
42	3	"	YBHH18010	BOLT, HEX HEAD, 9/16" X 1-3/4" GR. 5,
43	1	"	YBHH18115	BOLT, HEX HEAD, 9/16"-12 X 2-1/2" GR. 5, ZINC
44	84	112	YBHH20020	BOLT, 5/8" X 1-3/4" GR. 5
45	2	"	YBHH24050	BOLT, 3/4" X 3" GR. 5
46	16	"	YBCR16010	CARR. BOLT, 1/2" X 1-1/2" GR. 5
47	2	"	YBTE10030	TURNUED EYE BOLT, 5/16" X 3"
48	2	"	YWFL12005	WASHER, FLAT, 3/8" USS
49	1	"	YWFL24005	WASHER, FLAT, 3/4" USS
50	2	"	YWFL24010	WASHER, FLAT, SAE 3/4"
51	12	"	YWLO08005	WASHER, LOCK, 1/4"
52	2	"	YWLO12005	WASHER, LOCK, 3/8"
53	16	"	YWLO16005	WASHER, LOCK, 1/2"
54	5	"	YWLO18005	WASHER, LOCK, 9/16"
55	84	112	YWLO20005	WASHER, LOCK, 5/8"
56	2	"	YNHX12005	HEX NUT, 3/8"-16
57	5	"	YNHX18005	HEX NUT, 9/16"-12
58	2	"	YNRL24005	HEX NUT, REVERSIBLE-SIDE LOCK, 3/4"-10
59	2	"	YNTL12005	HEX NUT, TOP LOCK, 3/8"-16
60	16	"	YNTL16005	HEX NUT, TOP LOCK, 1/2"-13
61	84	112	YNTL20005	HEX NUT, TOP LOCK, 5/8"-11
62	1	"	YNTL24005	HEX NUT, TOP LOCK, 3/4"-10
63	2	"	YNSL24010	HEX NUT, SLOTTED, 3/4"-16
64	1	"	16SV44	TIGHTENER SPACER
65	1	"	HGV43	PRIMARY TIGHTENER SPACER

**NOTE: \* MEANS NOT SHOWN**

**— MEANS NOT USED ON THIS MODEL**

**" MEANS SAME AS PREVIOUS MODEL**

# FIGURE 14

## SUPERIOR GEARBOX LEFT

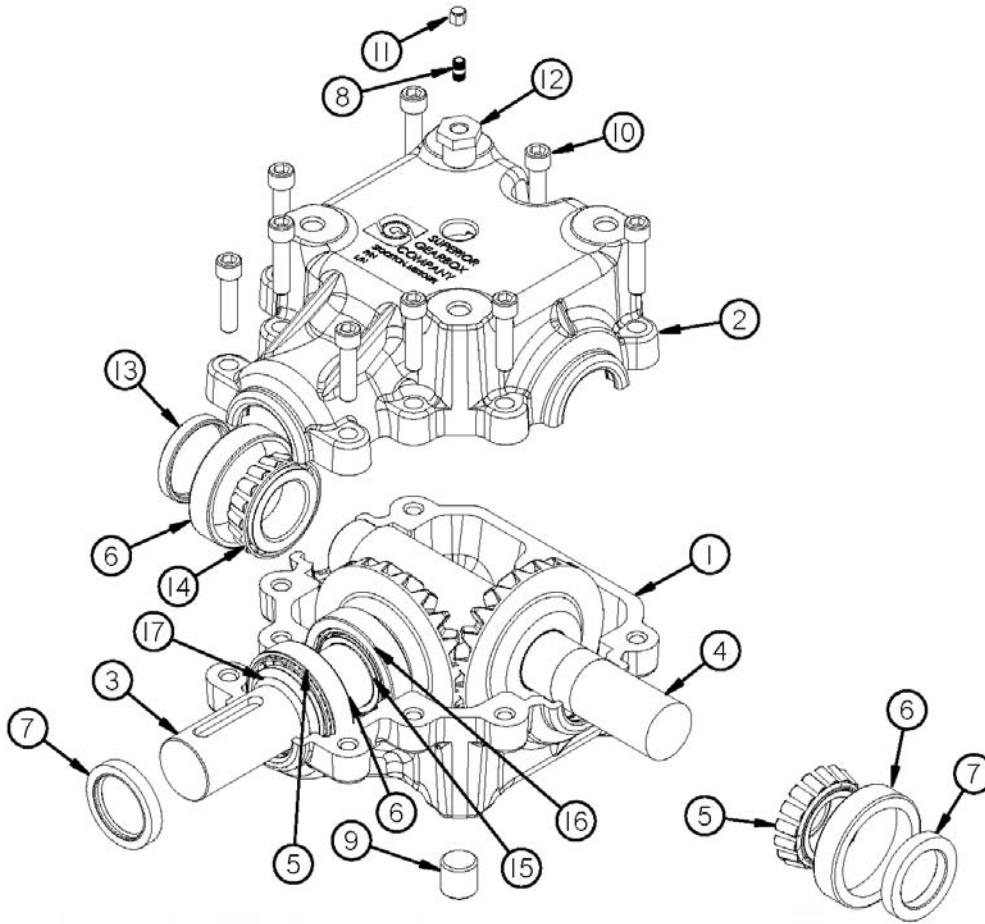

<u>ITEM</u>	<u>QTY</u>		<u>PART #</u>	<u>DESCRIPTION</u>
	<u>425</u>	<u>550</u>		
1	1	"	HGV88	BOTTOM HOUSING
2	1	"	HGV89	TOP HOUSING
3	1	"	HGV90	OUTPUT SHAFT
4	1	"	HGV105	INPUT SHAFT
5	2	"	HGV91	BEARING CONE (625581)
6	3	"	HGV92	BEARING CUP (625520)
7	2	"	HGV93	SEAL (617285)
8	1	"	23N288	3/8 NIPPLE
9	1	"	HGV95	PLUG (1/2-14 NPT)
10	9	"	YSHS12012	SOCKET HEAD CAP SCREW, 3/8" -16 X 2-1/4"
11	1	"	17G58	VENT
12	1	"	JB82	BUSHING (1/2 NPT To 3/8NPT)
13	1	"	HGV99	CAP
14	1	"	HGV94	BEARING CONE (625580)
15	1	"	HGV97	BEARING CONE (603782)
16	1	"	HGV112	BEARING CUP (603720)
17	1	"	HGV98	RETAINING PING (603493)
*	1	"	HGV58	COMPLETE GEARBOX LEFT

**NOTE: \* MEANS NOT SHOWN**

**" MEANS SAME AS PREVIOUS MODEL**



# FIGURE 15

## SUPERIOR GEARBOX RIGHT

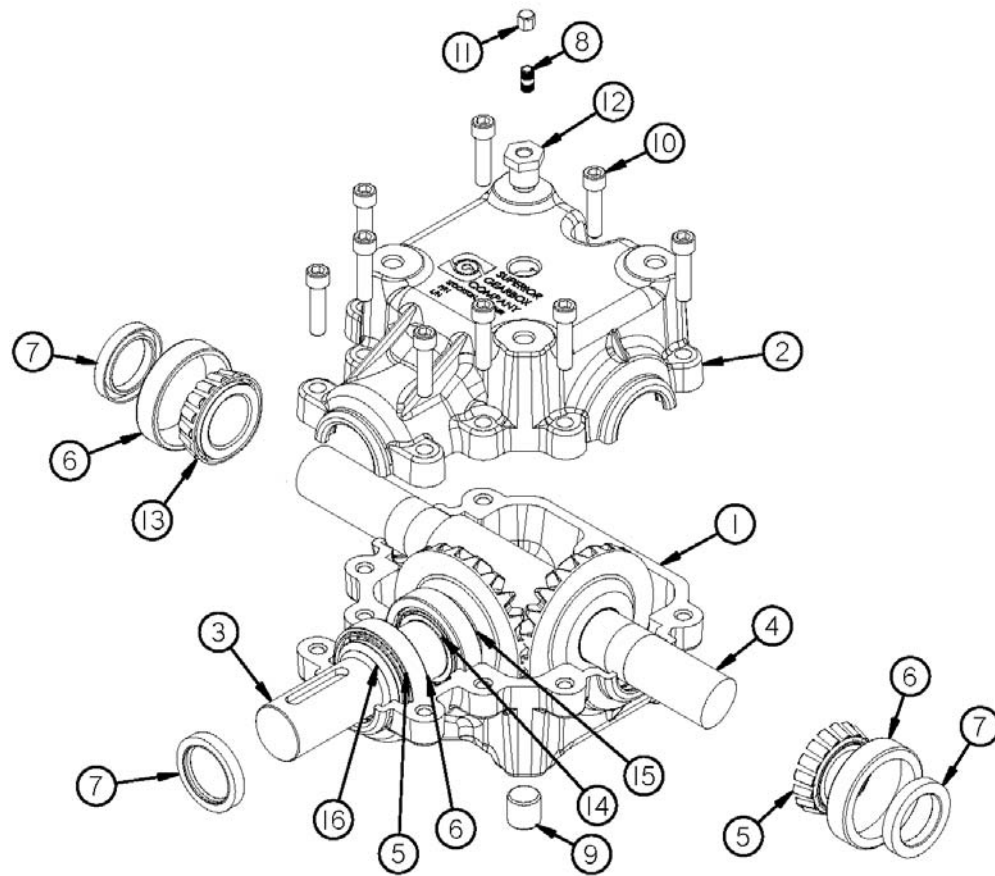

	<u>QTY</u>		<u>PART #</u>	<u>DESCRIPTION</u>
<u>ITEM</u>	<u>425</u>	<u>550</u>		
1	1	"	HGV88	BOTTOM HOUSING
2	1	"	HGV89	TOP HOUSING
3	1	"	HGV90	OUTPUT SHAFT
4	1	"	HGV101	INPUT SHAFT
5	2	"	HGV91	BEARING CONE (625581
6	3	"	HGV92	BEARING CUP (625520)
7	3	"	HGV93	SEAL (617285)
8	1	"	23N288	3/8" NIPPLE
9	1	"	HGV95	Plug 1/2-14 NPT)
10	9	"	YSHS12012	SOCKET HEAD CAP SCREW, 3/8" -16 X 2-1/4"
11	1	"	17G58	VENT
12	1	"	JB82	BUSHING (1/2 NPT To 3/8 NPT)
13	1	"	HGV94	BEARING CONE (625580)
14	1	"	HGV97	BEARING CONE (603782)
15	1	"	HGV112	BEARING CUP (603720)
16	1	"	HGV98	RETAINING RING (603493)
*	1	"	HGV60	COMPLETE GEARBOX RIGHT

**NOTE: \* MEANS NOT SHOWN**  
**" MEANS SAME AS PREVIOUS MODEL**

# FIGURE 16

## CHAIN OILER

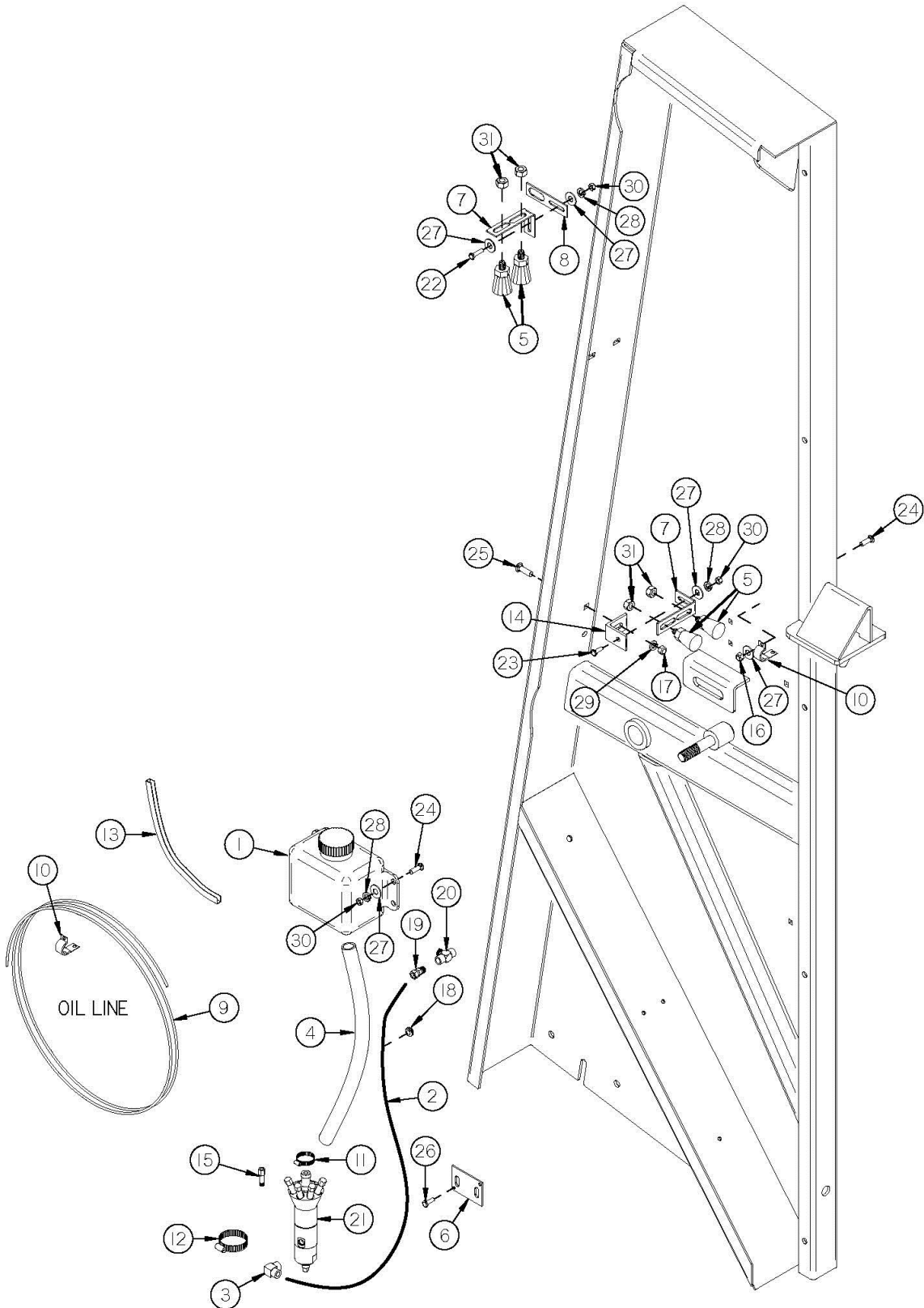

# FIGURE 16

## CHAIN OILER

<u>ITEM</u>	<u>QTY</u>		<u>PART #</u>	<u>DESCRIPTION</u>
	<u>425</u>	<u>550</u>		
1	1	"	HGV63	RESERVOIR
2	----	1	HGV64	HYDRAULIC HOSE 1/4" X 80"
*	1	----	GM501	1/4" X 29-3/4" HYDRAULIC HOSE
3	1	"	HGV65	O-RING/JIC ELBOW
4	4	"	HGV66	FILLER HOSE
5	4	"	HGV67	BRUSH
6	1	"	HGV135	OILER MOUNT
7	2	"	HGV69	BRUSH BRACKET
8	1	"	HGV70	BRACKET MOUNT
9	1	"	HGV71	OILER TUBE 5/32 OD
10	5	6	HGV72	SMALL TUBE HOLDER
11	2	"	HGV75	1" HOSE CLAMP
12	1	"	HGV74	2" HOSE CLAMP
13	1	"	HGV77	EDGING 12"
14	1	"	HGV170	ANGLE
15	4	"	HGV84	170-4515 MANIFOLD ASSEMBLY
16	3	"	YNL08005	HEX NUT, TOP LOCK, 1/4"-20
17	1	"	YNL12005	HEX NUT, TOP LOCK, 3/8"-16
*	1	-----	8613	OILER KIT (COMPLETE)
*	-----	1	HGV62	OILER KIT (COMPLETE)
18	1	"	8651	RUBBER GROMMET
19	1	"	BFR120	3/8" UNION ADAPTER (1404-6-6)
20	1	"	WM146	MALE - FEMALE PIPE TEE (5604-6-6)
21	1	"	HGV82	PUMP (COMPLETE)
*	1	"	HGV83	REPAIR KIT
22	11	"	YBHH08010	BOLT, 1/4" X 1" GR. 5
23	1	"	YBHH08100	BOLT, 1/4" X 3/4" GR. 5
24	7	"	YBCR08040	CARR. BOLT, 1/4" X 3/4" GR. 5
25	1	"	YBCR12010	CARR. BOLT, 3/8" X 1" GR. 5
26	2	"	YSDR08015	1/4"-20 X 1/2" HEX WASHER HEAD SLOT THRD ROLL SCREW, ZINC
27	11	"	YWFL08005	WASHER, FLAT, 1/4" USS
28	6	"	YWLO08005	WASHER, LOCK, 1/4"
29	1	"	YWLO12005	WASHER, LOCK, 3/8"
30	6	"	YNHX08005	HEX NUT, 1/4"-20
31	1	"	YNHX16005	HEX NUT, 1/2"

**NOTE: \* MEANS NOT SHOWN**

**" MEANS SAME AS PREVIOUS MODEL**

**— MEANS NOT USED ON THIS MODEL**

# FIGURE 17

## OPTIONAL LIGHTING

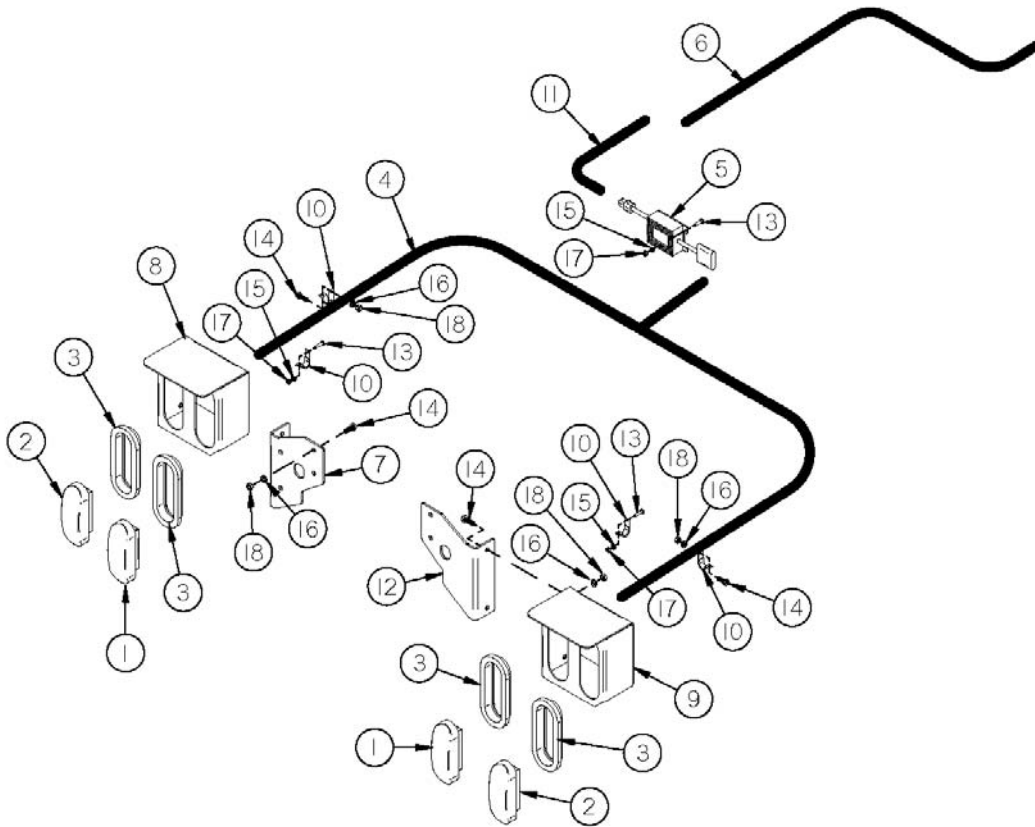

	<u>QTY</u>			
<u>ITEM</u>	<u>HP425</u>	<u>HP550</u>	<u>PART #</u>	<u>DESCRIPTION</u>
1	2	"	S310	RED TAIL LIGHT
2	2	"	S309	YELLOW HAZARD LIGHT
3	4	"	S308	RUBBER LIGHT MOUNT
4	1	"	56N155	TAIL LIGHT LOOM
5	1	"	S441	LIGHT MODULE
6	1	"	1140	FLASHER MODULE LOOM
7	1	"	HGV137	LIGHT BRACKET MOUNT LEFT
8	1	"	55N61	LIGHT BRACKET LEFT
9	1	"	55N62	LIGHT BRACKET RIGHT
10	14	"	55N64	METAL CUSHIONED CABLE CLAMPS
11	1	"	BFR666	EXT. LIGHT HARNESS
12	1	"	HGV136	LIGHT BRACKET MOUNT RIGHT
13	5	"	YBHH08010	BOLT, 1/4" X 1" GR. 5
14	10	"	YBHH12010	BOLT, 3/8" X 1" GR. 5
15	5	"	YWLO08005	WASHER, LOCK, 1/4"
16	10	"	YWLO12005	WASHER, LOCK, 3/8"
17	5	"	YNHX08005	HEX NUT, 1/4"-20
18	10	"	YNHX12005	HEX NUT, 3/8"-16

**NOTE: " MEANS SAME AS PREVIOUS MODEL**

# FIGURE 18

## OPTIONAL REAR PAN

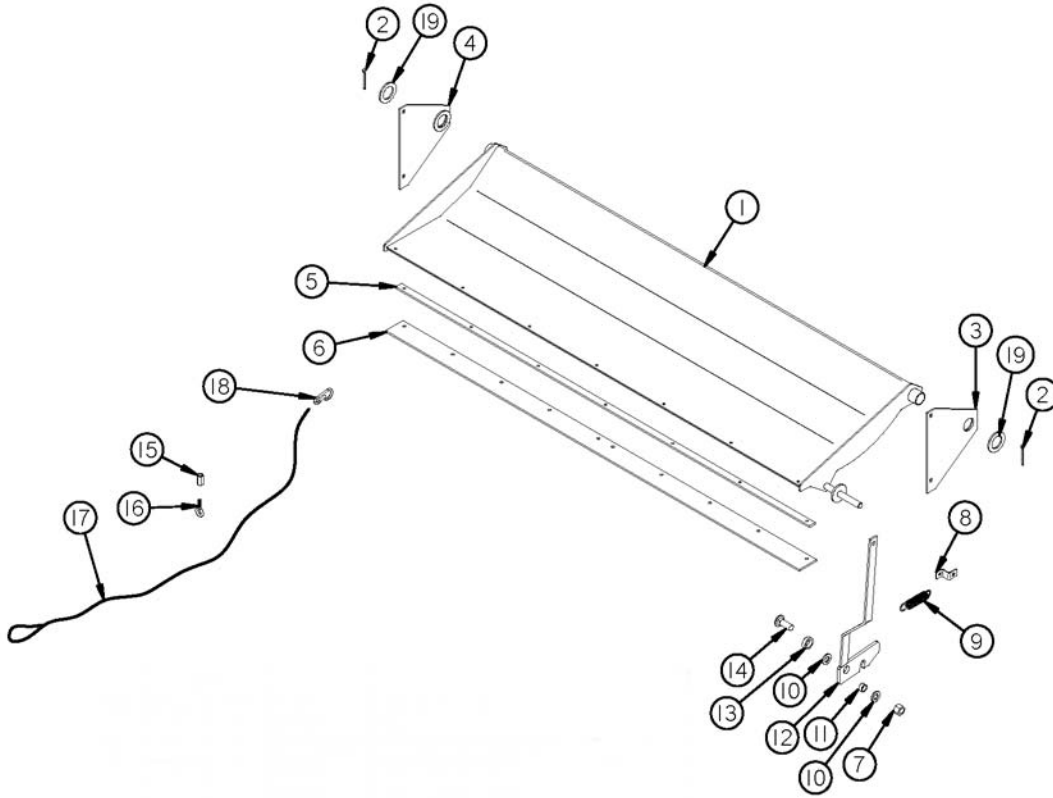

ITEM	QTY		PART #	DESCRIPTION
	HP425	HP550		
1	1	"	42N127	PAN
2	2	"	YPCT06020	COTTER PIN, 3/16" X 2"
3	1	"	42N128	PAN PLATE LEFT
4	1	"	42N129	PAN PLATE RIGHT
5	1	"	42N130	PAN STRAP
6	1	"	42N131	RUBBER
7	1	"	YNL24005	HEX NUT, TOP LOCK, 3/4"-10
8	1	"	F69	BRACKET
9	1	"	ST36	SPRING
10	2	"	T73	WASHER
11	1	"	42N132	LATCH BUSHING
12	1	"	42N133	LATCH
13	1	"	42N134	LATCH SPACER
14	1	"	YBCR24003	CARR. BOLT, 3/4" X 2-1/2" GR. 5
15	1	"	YNCO12005	HEX NUT, COUPLING, 3/8"-16 X 1-1/8"
16	1	"	YBTE12005	TURNT EYE BOLT, 3/8" X 1"
17	1	"	42N136	ROPE (18')
18	1	"	YMSN10005	MISC, SNAP HOOK, 5/16
19	2	"	56N170	PAN WASHER

**NOTE: " MEANS SAME AS PREVIOUS MODEL**

## FIGURE 19

### PTO 1000 RPM (425-550)

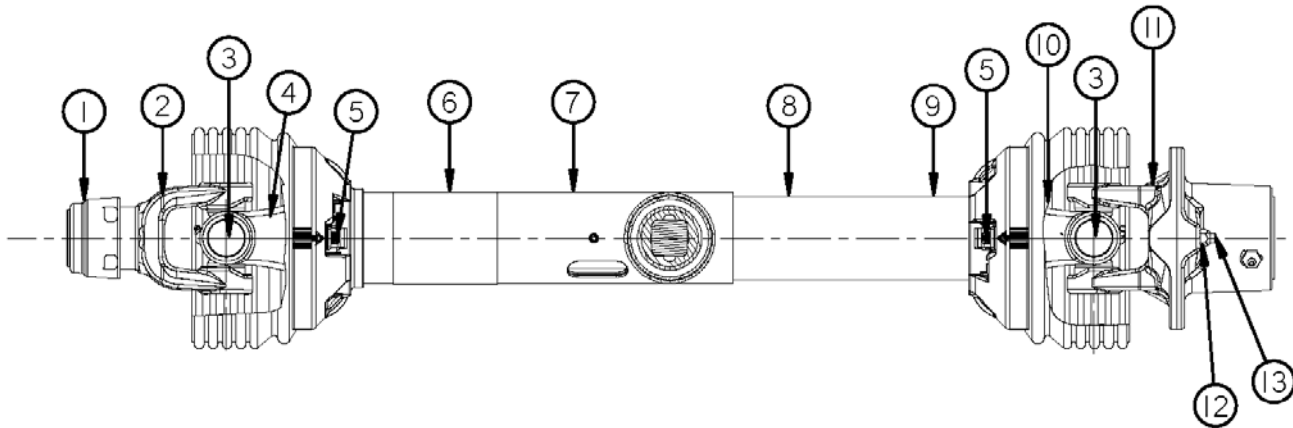

<u>ITEM</u>	<u>1000RPM (1-3/8)</u>	<u>1000 RPM (1-3/4)</u>	<u>DESCRIPTION</u>
1	16SV274	16SV275	AUTO-LOCK REPAIR KIT
2	55N68	55N69	AUTO-LOCK YOKE ASSEMBLY
3	16SV179	"	35R CROSS & BEARING KIT
4	42N116	"	YOKE & SHAFT
5	16SV181	"	NYLON REPAIR KIT
6	16SV283	"	SAFETY SIGN
7	42N117	"	OUTER GUARD
8	42N118	"	INNER GUARD
9	16SV286	"	SAFETY SIGN
10	42N119	"	YOKE, TUBE, & SLIP SLEEVE
11	42N120	"	OR BALL SHEAR ASSEMBLY
12	YNTL10005	"	HEX NUT, TOP LOCK, 5/16"-18
13	YBHH10070	"	SHEAR BOLT 5/16" x 2" GR. 5 (1000 RPM)
*	55N72	55N73	JOINT & SHAFT HALF ASSM.W/GUARD
*	55N74	55N75	JOINT & SHAFT HALF ASSM.
*	55N76	"	JOINT & TUBE HALF ASSM. W/GUARD
*	55N77	"	JOINT & TUBE HALF ASSM.
*	55N78	55N79	COMPLETE PTO
*	S402	"	PTO SAFETY MANUAL

**NOTE:** \* MEANS NOT SHOWN  
 — MEANS NOT USED ON THIS MODEL  
 " MEANS SAME AS PREVIOUS MODEL

**FIGURE 20**  
**PTO 540 RPM (425)**

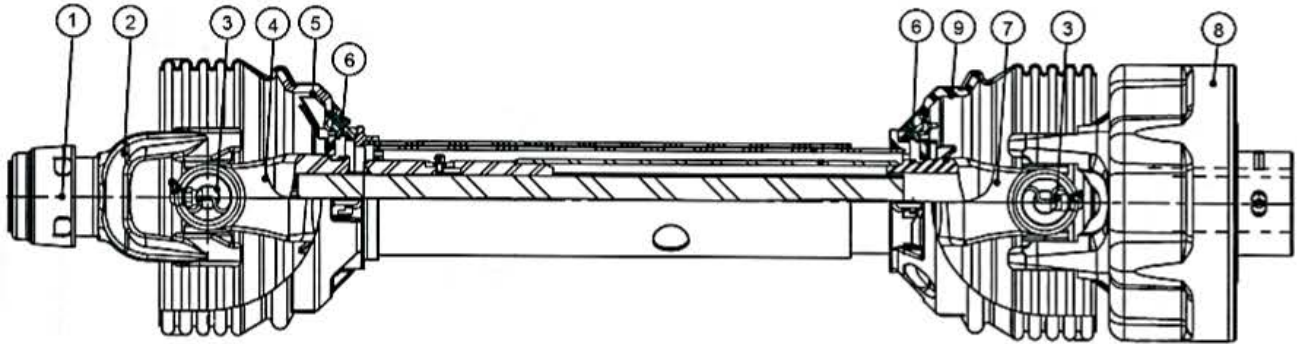

<b><u>ITEM</u></b>	<b><u>QTY</u></b>	<b><u>PART #</u></b>	<b><u>DESCRIPTION</u></b>
1	1	16SV274	SAFETY SLIDE LOCK REPAIR KIT (1-3/8")
2	1	42N115	AUTO-LOCK YOKE ASSM 1-3/8-6
3	2	16SV179	35R CROSS & BEARING KIT
4	1	61375	YOKE & SHAFT (1.31-20 SPLINE)
5	1	61376	OUTER GUARD
6	2	16SV383	GUARD REPAIR KIT
7	1	61378	YOKE, TUBE & SLIP SLEEVE
8	1	61379	OVERRUNNING AUTOMATIC CLUTCH
9	1	61377	INNER GUARD
*	1	61371	JOINT & SHAFT ASSY W/GUARD
*	1	61372	JOINT & SHAFT ASSY
*	1	61373	JOINT & TUBE ASSY W/GUARD
*	1	61374	JOINT & TUBE HALF ASSY
*	1	60255	COMPLETE PTO

**NOTE: \* MEANS NOT SHOWN**

**FIGURE 21**  
**OPTIONAL TANDEM (550)**

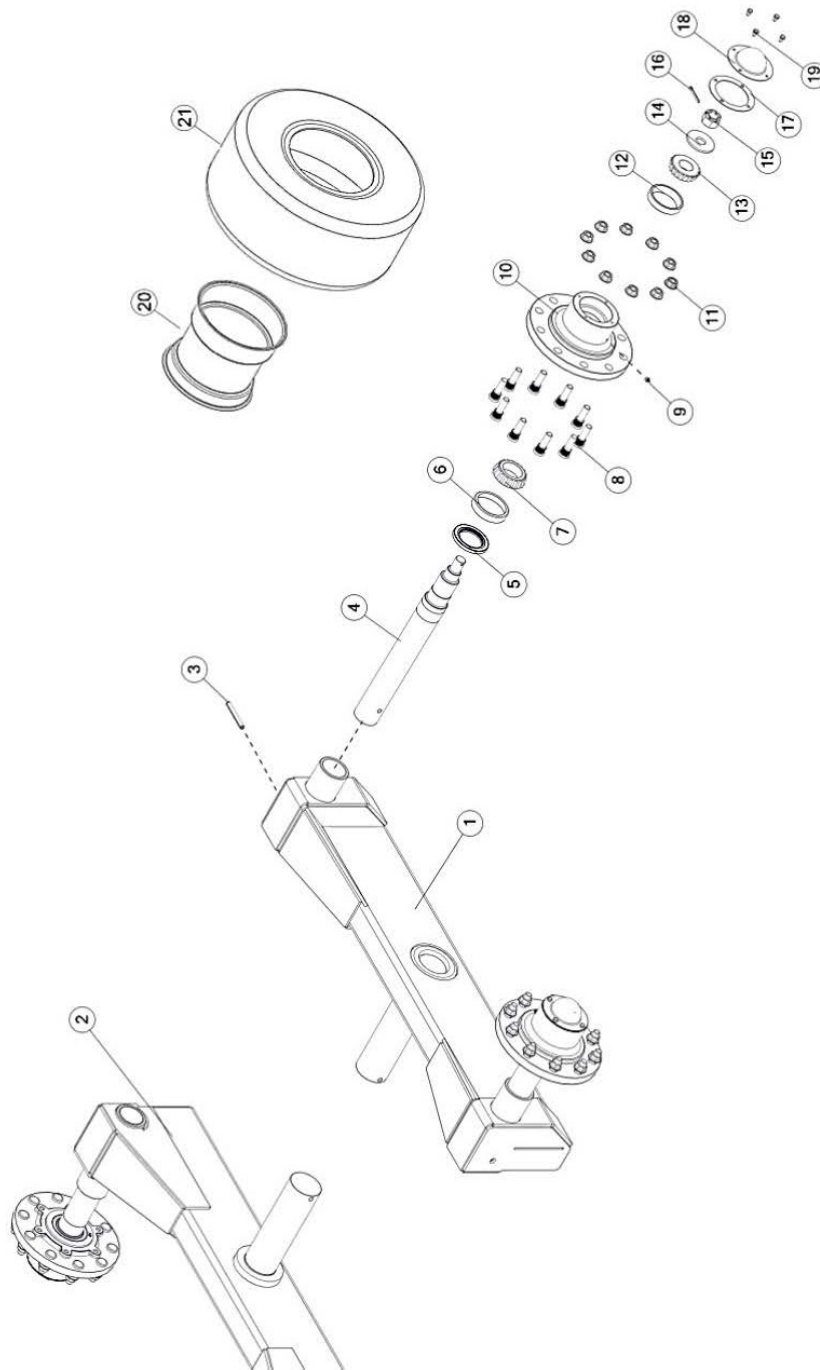



**FIGURE 21**  
**OPTIONAL TANDEM (550)**

<b><u>ITEM</u></b>	<b><u>QTY</u></b>	<b><u>PART #</u></b>	<b><u>DESCRIPTION</u></b>
1	1	59595	TANDEM AXLE LEFT
2	1	59596	TAMDEM AXLE RIGHT
3	4	YPEX16020	EXPANSION PIN, 1/2" X 4"
4	4	FBC31	TANDEM SPINDLE
5	4	60N5	SEAL--600 BUSHEL
6	4	60N6	INNER RACE--600 BUSHEL
7	4	60N7	INNER BEARING--600 BUSHEL
8	40	YBSD24010	STUD BOLT, 3/4-16UNF X 2-3/4 (3/4 SHOULDER)
9	4	BFR28	1/8" NPT GREASE ZERK
10	4	54508	871 HUB WITH KOYO BEARINGS
11	40	60N14	HEX FLANGE NUT, 3/4-16 UNF-28, GR 8
12	4	60N10	OUTER RACE--600 BUSHEL
13	4	60N9	OUTER BEARING--600 BUSHEL
14	4	60N2	SPINDLE WASHER
15	4	YNCA36005	HEX NUT, CASTLE, 1-1/4"-12
16	4	YPCT07005	COTTER PIN, 7/32 X 2
17	4	56234	HUB CAP GASKET
18	4	60N11	HUB CAP--600 BUSHEL
19	16	YBHH10020	BOLT, 5/16 X 1/2 GR 5
20	4	FBC35	22.5 X 20 10 BOLT W22-06900R P10
21	4	59918	600/50R22.5, TIRE

**H&S MFG. CO.**

products approved

for the

**FEMA**

**SEAL OF QUALITY**

